

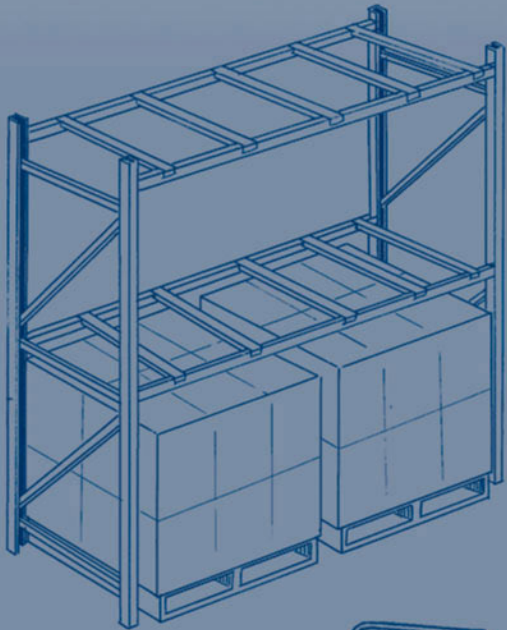

USAID
FROM THE AMERICAN PEOPLE

Guidelines for Warehousing Health Commodities

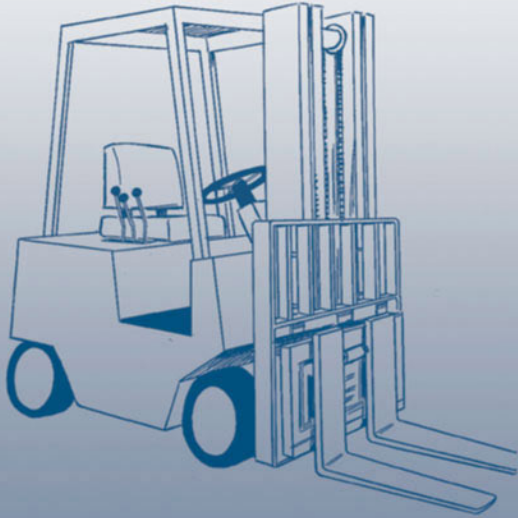

DELIVER
No Product? No Program. Logistics for Health

Guidelines for Warehousing Health Commodities



USAID
FROM THE AMERICAN PEOPLE



DELIVER
No Product? No Program. Logistics for Health

DELIVER

DELIVER, a six-year worldwide technical assistance support contract, is funded by the U.S. Agency for International Development (USAID).

Implemented by John Snow, Inc. (JSI), (contract no. HRN-C-00-00-00010-00) and subcontractors (Manoff Group, Program for Appropriate Technology in Health [PATH], and Social Sectors Development Strategies, Inc.), DELIVER strengthens the supply chains of health and family planning programs in developing countries to ensure the availability of critical health products for customers. DELIVER also provides technical management of USAID's central contraceptive management information system.

This document does not necessarily represent the views or opinions of USAID. It may be reproduced if credit is given to John Snow, Inc./DELIVER.

Recommended Citation

John Snow, Inc./DELIVER. 2005. *Guidelines for Warehousing Health Commodities*. Arlington, Va.: John Snow, Inc./DELIVER, for the U.S. Agency for International Development.

Abstract

These guidelines were written for anyone trying to meet and solve the challenges of operating a warehouse today. They are an important reference tool for managers and staff, whether they are constructing a new warehouse, implementing a new warehouse system, or redesigning their current system.

The guidelines consist of four sections—human resource, layout planning, racking systems and material handling equipment, and warehouse management system. The text is augmented by detailed illustrations, including a proposed organogram for staff.

Guidelines for Warehousing Health Commodities provides up-to-date information on all aspects of warehousing.



DELIVER

John Snow, Inc.
1616 North Fort Myer Drive, 11th Floor
Arlington, VA 22209 USA
Phone: 703-528-7474
Fax: 703-528-7480
Email: deliver_project@jsi.com
Internet: deliver.jsi.com

Contents

Acknowledgements	vii
Introduction	ix
Human Resource Planning	1
General Strategy	1
Identify Basic Warehousing Activities and Activity Tasks	1
Personnel Required for a Typical Warehouse	2
Estimating Time Requirements for Activities/Tasks	4
Training Requirements	5
Layout Planning	7
Importance of Layout Planning	7
General Steps in Layout Planning	7
Step 1: Identify Warehouse Activities	7
Step 2: Determine Space Requirements	8
Step 3: Estimate Shipping and Receiving Staging Requirements	10
Summary of Space Requirements for Shipping and Receiving	14
Step 4: Determine Space Requirements for an Ideal Layout for Storage and Retrieval	14
Step 5: Establish a Realistic Layout by Reconciling Space Requirements with Existing Constraints	18
Step 6: Determine Space Requirements and Ideal Layout for Storing Unusable Items	20
Racking Systems and Material Handling Equipment	23
Overview	23
What Is a Material Handling System?	24
Racking and Shelving Systems	24
Racks	24
Shelving	24
Rack Planning Considerations	25
Volume	25
Pallets/Containers	25
Equipment Clearance (Dimensions)	26
Building Dimensions	26
Warehouse Floors	27
General Categories (Types) of Rack Systems	28
Large Products Storage Systems	29
Pallet Storage Systems Selection	36
Dynamic Small Product Storage/Picking Systems	36
Small Static Product Storage Systems	37

Material Handling Equipment	41
Introduction and Background	41
General Selection Criteria to Determine Equipment Needs	42
Lift Truck Types/Classifications	44
Warehouse Checklist	52
Key Warehouse Planning Issues to Consider for Warehouse Planning (new and existing warehouse buildings):	52
Warehouse Management Systems	55
Overview	55
What Storage and Distribution Tasks Does a WMS Support?	55
Benefits of a WMS	55
Components of a WMS	56
Software	57
Radio Frequency Communications Equipment	59
Bar Coding Technology	60
Background and Terminology	60
What Is a Bar Code?	60
What Components Are Used in Bar Code Technology?	60
When Should You Consider Bar Coding?	66
Barcoding Equipment Manufacturers and Dealerships	68
Forming a WMS Project Team	68
Developing an Effective Business Case for a WMS	69
Quantifying Benefit of a WMS	69
Financial Decision-Making Approach	70
Analyzing Warehouse Needs	74
Defining the WMS Solution Type	74
Testing the WMS	76
Training Users	76
Rollout	77
Computerized WMS Solutions	77
Lessons Learned	79
Accurate Stock on Hand Data Are the Key to Implementation Success	79
Local Technical Support Is Critical to Continued WMS Operations	79
References	81
Appendix 1: WMS Reports	83
Appendix 2: WMS Tools	89

Figures

1. Suggested management/supervisory structure for warehouse personnel.....	3
2. Typical layout for receiving/shipping activities	9
3. Sample layout using selective pallet racks and bin shelving.....	17
4. Selective pallet rack.....	29
5. Single bay with pallets.....	29
6. One row of connecting racks (2 bays) with 3 multi-shelves	30
7. Common rack beam sections (rolled-formed left, structural right).....	30
8. Common rack column sections	30
9. Rack column section with teardrop connector	30
10. Selective pallet rack bay with two pallets	31
11. General pallet rack clearance requirements	32
12. Pallet rack clearance for straddle-type lift trucks	32
13. Double-deep rack with double-deep fork lift	33
14. Drive-in rack three-deep	33
15. Drive-through rack three deep	34
16. Push back rack system	34
17. Gravity flow rack	35
18. Horizontal carousel	36
19. Vertical carousel	37
20. Two general types of shelving, open and closed	38
21. Modular storage: drawer cabinet with partitions	38
22. Gravity flow racks	39
23. Manual low-lift hand truck	45
24. Electric low-lift truck	45
25. Low-lift electric rider	45
26. Counterbalance lift truck—rider	46
27. Counterbalance lift truck—stand-up (electric).....	46
28. Parts of a counterbalance forklift	47
29. General principles of counterbalance lift truck.....	48
30. Right-angle turning radii	49
31. Standard straddle truck	50
32. Double reach straddle truck	50
33. Stand up turret truck	51
34. Hybrid turret truck	51
35. Warehouse rolling ladder	52
36. WMS network.....	59

Tables

1: Sample Time Requirements for the Receiving Activity	4
2: Sample Worksheet for Estimating Shipment Receiving and Staging Space Requirements: Complete Data Method	11
3: Sample Worksheet for Estimating Shipment Receiving and Staging Space Requirements: Partial Data Method	12
4: Estimation of Staging Space Requirements	13
5: Storage Methods by Commodity Type	15
6: Sample Worksheet for Estimating Bulk Storage Space Requirements Based on Complete Data	16
7: To Estimate Space Requirements	17
8: Warehouse Management System Data	57
9: WMS Software Functions	58
10: Warehouse Management System Reports	58
11: Warehouse Labor Types	69
12: Potential Cost Savings from WMS	70
13: Present Value Calculation Example	72
14: Sensitivity Analysis for Net Present Value Calculations	73
15: WMS Solutions	79

Acknowledgements

The authors of the *Guidelines for Warehousing Health Commodities* wish to acknowledge the contributions and support of the many people who took the time to meet with the authors and provide essential warehouse information. Without their input and shared experiences, this manuscript would have been difficult to complete. A few of the many people and organizations deserving special thanks include the John Snow, Inc./DELIVER staff, who reviewed the document and provided fresh ideas and sound warehouse concepts. Their willingness to give countless hours of valuable input was instrumental to completing this document.

We would like to especially thank Barbara Felling for her invaluable help. She reviewed the manual thoroughly several times and provided excellent technical comments for all sections.

Additionally, special thanks go to organizations, including Advance Storage Products, Yale Industrial Trucks, and Crown Agents/United Kingdom, who provided invaluable technical insights during the development of the guidelines.

A project of this scope involves inputs and contributions from so many people that it is impossible to acknowledge all the names and organizations, and the authors would surely unwittingly omit many if we attempted to do so. There were many organizations and individuals who contributed to the assessment in many different ways, and we are sincerely grateful for the in-depth and extensive assistance received from all.

Special thanks goes to Joe Azar for his wonderful illustrations. Joe worked many hours on the manual, and he was always available for assistance.

Finally, we thank the communications team, managed by Chris Wright, for their hard work on this important document. Gus Osorio, art director, was the layout designer and Pat Shawkey was the editor.

Tim O'Hearn
Jim Eberle
Hany Abdallah
Leslie Rock

August 2005

Introduction

The *Guidelines for Warehousing Health Commodities* was developed to help support anyone interested in finding solutions to today's warehousing challenges. These guidelines are an informational reference tool for logistics advisors, as well as warehouse managers and staff who are considering the construction of a new warehouse, implementing a new warehouse system in an existing facility, or redesigning their current system. In this manual you will find information about how to implement a practical and efficient warehouse system. Although this warehouse guide provides extensive up-to-date information, it cannot relate to all aspects of warehousing. It does, however, provide detailed information in four primary warehouse areas: (1) human resource planning, (2) layout planning, (3) racking systems and material handling equipment, and (4) warehouse management systems.

The *Guidelines* has four main sections, and includes illustrations of the subject matter being discussed.

Human Resource Planning: People are the most important part of any warehouse operation, and determining the kind of skills and the number of people needed is a significant activity for warehouse management to plan and implement. This section reviews human resources planning and the steps to consider when estimating staff requirements. An overall strategy identifies the basic activities that relate to warehouse operations and the staff required to complete these activities. In addition to identifying the basic activities, we included an example on how to estimate the time required to complete specific activities or tasks. An organogram displays a general warehouse staff structure.

Layout Planning: This section includes the importance and the objectives of layout planning, in addition to a comprehensive review of the steps that must be taken to complete this activity. This section also includes a methodology for estimating the volume requirements for staging and storing commodities. It offers guidance for organizing commodities within the warehouse.

Racking Systems and Material Handling Equipment: Materials, supplies, and other products are an essential part of most warehouses. As the technology improves in both computing and material handling, managers need to know what resources are available, how certain equipment is used, and how to understand the essentials of materials management. Thus, careful planning and management of these materials are fundamental to the success of any warehouse operation. This section discusses topics related to effective materials management, including an overview of warehousing and its current responsibilities, and a description of a material handling system. It also includes the critical planning steps necessary when you prepare to implement a rack/bin system and material handling equipment, general categories, and descriptions of rack and material handling equipment. Detailed illustrations of the equipment enhance the text.

Warehouse Management System: Today the availability of timely, accurate, and inexpensive information is opening the door to quality and productivity improvements in warehousing. This section presents an overview of warehouse management systems (WMS). It also discusses technologies that integrate software, bar coding equipment, and radio frequency communications into a WMS. This section reviews warehousing tasks that WMS supports, the five major benefits of implementing a WMS, the major components of a WMS, the essential data groups and items, and WMS reports. Also included are warehouse transactions that can be linked electronically to WMS software in real-time, such as bar

coding technology and scanners. Finally, this section presents a comprehensive financial analysis of a WMS.

We hope that you will find these guidelines beneficial for all aspects of warehouse operations. It is important to remember that these guidelines are not scripted disciplines but are options for improving warehouse management. The guidelines are building blocks for effective warehouse management; they present the frameworks, methodologies, and tools essential for the design and implementation of a warehouse system that meets your specific needs.

Human Resource Planning

People are a critical component of any warehousing operation. Space and equipment, although important, do not affect the quality of warehousing as much as the people. People will determine whether your warehouse is productive or not.

The warehouse planner's single most important activity is to determine the type and number of people needed to operate a warehouse. Hiring too few people can be as damaging as hiring too many. Too few staff can result in unacceptable order turnaround times and customer dissatisfaction. Too many staff can result in poor productivity and increased cost. Finding the correct mix is critical.

General Strategy

To estimate the human resource requirements to run a warehouse, you can follow this strategy:

1. Identify the basic warehouse activities (e.g., receiving, storage, order-picking, etc.).
2. Divide each activity into component tasks (e.g., receiving tasks might include starting up the lift-truck, unloading a pallet from the truck, filling out forms, etc.).
3. Identify the typical types of personnel that work in a warehouse, and associate these individuals with particular activities/tasks.
4. After this is complete, specify a time requirement for each task (e.g., it takes an average of 15 minutes each day to start the lift-truck).
5. Determine how much time is required to perform each task and who should perform the task.
6. With this information, calculate the number of personnel needed for all activities.

Identify Basic Warehousing Activities and Activity Tasks

You usually find ten types of basic warehousing activities.

- | | |
|-----------------------------|-----------------------|
| 1. receiving/unloading | 6. order picking |
| 2. inspection | 7. checking |
| 3. inventory control | 8. packing |
| 4. storage | 9. staging (possibly) |
| 5. replenishment (possibly) | 10. shipping/loading. |

Each activity has one or more tasks. Though the number of tasks will vary from situation to situation, there is a common set of tasks for all warehouses.

Receiving: Unload supplier vehicles; move materials to inspection area.

Inspection: Draw sample from shipment and inspect (or arrange for inspection) to ensure compliance with specifications on purchase orders; report on status of inspection to purchasing and inventory control; count material and check against shipping invoice; report on status of count to inventory control. Note any discrepancies.

Inventory control: Operate manual or automated inventory control system; provide directions for moving supplies to/from storage; provide information to management on receipts, issues, and stock balances; reconcile inventories to book or automated records; coordinate physical inventories.

Storage: Move incoming supplies to special picking location (if one exists) and/or storage location; confirm movement of supplies with inventory control.

Replenishment (assumes special picking location exists): Move supplies from storage location to special picking location; confirm movement of supplies with inventory control.

Order picking: Select items from special picking location or storage based on the pick list; confirm selection of items with inventory control; perform physical inventories.

Checking: Check picked orders for accuracy of item, quantity, and condition; compare quantity, quality, labeling, and address with customer's order to ensure compliance.

Packaging: Package orders for customers; mark or label containers that hold customer orders.

Staging: Arrange orders according to customer and/or carrier that will transport products.

Shipping: Load outbound carrier, complete necessary paperwork, and report to inventory control.

Personnel Required for a Typical Warehouse

A typical warehouse is comprised of supervisors, records clerks, and floor personnel. In most cases, only two supervisors and two record clerks are needed. The number of floor personnel will depend on the person-power needed for each activity.

Following are the suggested personnel needed to operate a typical warehouse with moderate turnover (see figure 1):

General Manager (one): The General Manager is responsible for the overall performance of the warehouse, including customer service, warehouse operations, and information systems. The General Manager must also liaise with the procurement and transport sections of the organization (assuming these activities are managed elsewhere in the organization). This person is responsible for managing and directing all activities related to the warehouse, including planning and scheduling all distribution services.

Inventory control clerk (one) (can also do shipping and receiving activities if time requirements are acceptable): The inventory control clerk's primary responsibility is to maintain and update inventory records, usually through an automated system. This person also creates inventory management procedures, when necessary, and coordinates the annual physical inventory. He or she responds to information enquires from others, when necessary, and develops all necessary reports and documentation to facilitate accurate inventory control.

Shipping and receiving clerk (one) (unless inventory control clerk assumes responsibility for shipping and receiving activities): The shipping and receiving clerk ensures that all shipping and receiving documents and functions are completed. This person also coordinates with customers and transport, as required.

Pharmacist (one, possibly): If the warehouse will be storing medications and other medical supplies, a pharmacist may be required to ensure the quality of products received, stored, and issued.

Warehouse operations supervisor (one): The warehouse operations manager has general managerial responsibility for all routine warehousing activities and for all floor personnel, including forklift operators, order fillers/pickers, checkers, loaders/unloaders, and equipment maintenance and repair persons. This person is responsible for maintaining the product locator system and coordinating the picking and put-away operations, as well as all routine physical inventories.

Forklift operator/storage person (number depends on estimated time requirements for storing/retrieving materials to/from pallet racks): Forklift operators are responsible for operating a forklift to move, relocate, and stack materials. They perform minor maintenance of the forklift and other related equipment. They can also be asked to assist in filling orders, if needed.

Order filler/picker (number depends on estimated time requirements for picking orders): Order fillers/pickers fill customer orders and deliver the items that make up the order to a staging area or delivery platform. They are also responsible for conducting physical inventories as directed. Order filler/pickers may also perform packaging/assembling orders for shipment.

Checker (number depends on estimated time requirements for checking picked orders): Checkers count all products for both inbound and outbound freight; and check the quantity, quality, labeling, and addressing of orders. Checkers may also be responsible for packaging and assembling orders for shipment.

Loader/unloader (number depends on estimated time requirements for loading and unloading materials): Loaders/unloaders move materials from vehicles to receiving area and from shipping area to vehicles. Loader/unloaders may also be asked to assist in packaging, repairing pallets, cleaning, and other janitorial tasks.

Equipment maintenance and repair person (one, if warranted): Equipment maintenance and repair persons keep equipment in good working order, including, but not limited to, building generator, lighting, and materials handling equipment.

Figure 1. Suggested management/supervisory structure for warehouse personnel

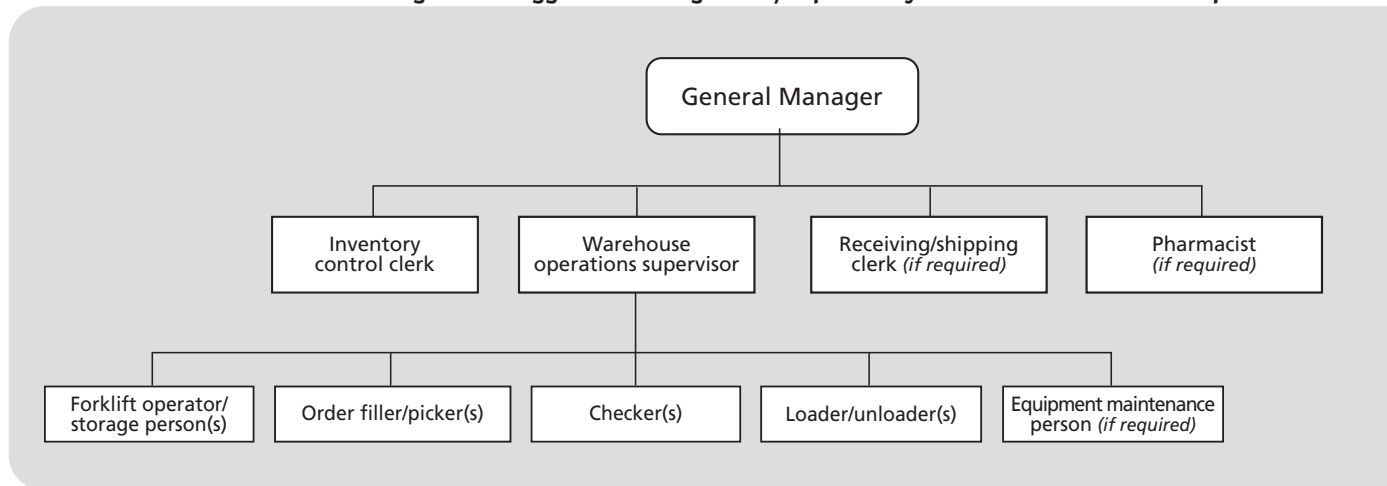

Estimating Time Requirements for Activities/Tasks

To estimate the number of staff required to operate a warehouse, you need to establish time requirements (or standards) for all tasks related to each activity. In general, there are two ways to determine time requirements: (1) observe how long it takes the staff to do each task, or (2) use a predetermined time standard. Standards have been developed by the U.S. Department of Defense but, in many cases, they are not applicable and are not considered here.

Estimating the time requirements for activities/tasks can be difficult. Table 1 displays the weekly time requirements for a fictional warehouse for all tasks related to the activity of *receiving*. Note that the example includes both repetitive and non-repetitive tasks. In this example, it was necessary for the warehouse to use a stopwatch to determine how much time it took to complete a typical repetitive task, and then multiply the resulting number by the number of times the task was repeated each week. For non-repetitive tasks, the warehouse estimated how much time was required for such tasks per week.

Table 1: Sample Time Requirements for the Receiving Activity

Task (type of task)	Formula for Calculating Time Requirement	Weekly Time Requirement	Responsible Staff
Unload materials from vehicles (repetitive).	Unload 1,000 boxes (1 cubic meter each) to pallet @ 3 minutes a box.	50 hours	Loader/unloader
Move materials to receiving or inspection area (repetitive).	Move 1,000 pallets to receiving area @ 1.5 minute a pallet.	25 hours	Loader/unloader
Take receiving documentation to shipping/receiving clerk and fill out necessary paperwork (repetitive).	Task takes approximately 30 minutes per day.	3 hours	Loader/unloader
Obtain new pallets and other operating supplies (non-repetitive).	Task is usually done quarterly @ 2 days each time.	2 hours	Loader/unloader
Maintain/repair materials handling equipment (non-repetitive).	Task is usually done twice yearly @ one week each time.	2 hours	Equipment maintenance person

Total time requirements for receiving activity:

Loader/unloader: 80 hours required per week

Equipment main. person: 2 hours required per week

Total staff requirements for receiving activity:

Loader/unloader: 80 hours weekly workload/40 hours per week per person = 2 loaders/unloaders required.

Equipment

maintenance person: 2 hours weekly workload/40 hours per week per person = 0.05 equipment maintenance persons required.

(**Note:** This assumes a 40-hour work week.)

It should be mentioned that time requirements calculated in this way do not include allowances for personal fatigue and routine delays/breaks. Adjustments must be made to the total time requirements to account for restroom breaks, coffee or tea breaks, personnel visits, machine malfunctions, etc. The warehouse may know what these adjustment factors are or they may use standard factors, such as 5 percent for light work and 15 percent for heavy work.

Forklift operator/storage person: Forklift operators must complete a forklift training program that teaches them how to handle materials, correctly operate the forklift, and perform routine maintenance. They must also understand the warehouse locator system. If forklift operators will assist order fillers, they should be given appropriate training in picking/filling orders.

Order filler/picker: Order fillers/pickers must understand the warehouse locator system and understand the labeling on each product stored in the warehouse. They must be trained to pick the correct amount of each item on a pick order and complete pick order paperwork. They must also be trained to count products in stock for physical inventories and to complete appropriate paperwork. If order fillers/pickers will be assisting in packaging and assembling orders, they should be trained to properly package an order and sort orders by customer or carrier.

Checker: Checkers must be trained to count orders properly and complete pick order paperwork. If checkers will be assisting in packaging and assembling orders, they should be trained to properly package an order and sort orders by customer or carrier.

Loader/unloader: Loaders/unloaders must be trained to load and unload vehicles correctly. They must also be taught how to use materials handling equipment (hand trolleys, more than likely). If they will be assisting in packaging and assembling orders, they should be trained to properly package an order and sort orders by customer or carrier.

Layout Planning

Importance of Layout Planning

The most critical factor in warehousing is space. How an organization organizes and uses space has a profound effect on the efficiency of the personnel and their ability to improve service delivery for their customers.

Layout planning is the discipline of assessing the space requirements of a warehouse or other storage facility and specifying how that space should be organized to facilitate identifiable warehouse activities.

The main objectives of layout planning are to—

- Use space efficiently.
- Promote the efficient handling of commodities.
- Provide economical storage.
- Provide flexibility to meet changing warehousing requirements.

This chapter presents a methodology for determining how to plan the layout in a warehouse or storage facility.

General Steps in Layout and Space Requirements Planning

You should consider taking three general steps when you plan the layout for a warehouse—

1. Identify warehouse activities that require layout planning.
2. Determine the space requirements and ideal layout for each warehouse activity.
3. Develop a realistic layout by reconciling space requirements with existing constraints.

Step 1: Identify Warehouse Activities

In a standard warehouse or storage facility, two main activities require space or layout planning:

- receiving/shipping
- storing/retrieval.

Because the shipping and receiving tasks are often performed in the same general location within the warehouse, they are often analyzed together.

- *Receiving* includes the tasks related to the acceptance of usable commodities from outside suppliers and the preparation of those commodities for storage in the warehouse.
- *Shipping* includes the tasks that help prepare usable commodities for shipment to customers and the placement of those commodities on vehicles for transport to the customers.

Storing/retrieval are activities associated with the actual (semi-permanent) storage of usable commodities in the warehouse, usually on pallets, shelves, and/or racks.

- *Storing* is the task of moving usable commodities from the receiving area and placing them in pre-defined locations within the warehouse (either on the floor, shelf, or rack).
- *Retrieval* is moving usable commodities from one or more locations (for example, the floor, shelves, or racks), and transporting them to the shipping area where they can be processed for shipment to customers.

The storage of unusable commodities is also a common activity that requires layout planning. This involves separating unusable from usable stock, and moving the unusable stock to a pre-defined location within the store (where the stock will remain until it can be evaluated and removed from the warehouse for proper disposal). Unusable stock is usually defined as commodities that have either expired or have been damaged and cannot be safely consumed by customers. Unusable stock may include items that were rejected during receiving/quality control inspection or items in stock that have expired or were damaged. Unusable stock can also include anything that cannot be used by the warehouse (e.g., broken furniture/equipment, broken pallets, and non-reusable packing materials).

When a layout plan is being developed, the storage of unusable commodities is often overlooked, but it may be just as important as receiving/shipping and storing/picking. This is especially true in dysfunctional warehouses where commodities often expire or become unusable. In warehouses where space has not been specifically allocated for storing items that can no longer be used, it is often necessary to use space that was dedicated for other activities to accommodate these items.

Note: In some warehouses, space must be allocated for house administration functions (e.g., reception, finance, procurement, and others). For this guide, it is assumed that you have a separate space to facilitate administrative functions, including space to conduct meetings.

Step 2: Determine Space Requirements

When you plan the space requirements for shipping and receiving, it is important for you to know that the activities for *shipping and receiving require more space than is usually thought necessary*. When analyzing space for shipping and receiving, consider the following:

- truck docking
- shipment receiving maneuvering
- shipment receiving.

Truck Docking Requirements

Space requirements for docking trucks, within or adjacent to the warehouse, are usually predefined. Normally, trucks are docked in one of two ways:

- at a 90° angle to the dock
- at less than a 90° (usually a 45°) angle to the dock.

When docking at a 90° angle, no space is required. In an unusual case when the angle is less than 90°, the space requirement is proportional to the angle of delivery. If the

angle is 45° , the amount of space required for each *docking space* is a triangular space approximately 4.25 meters (at entrance to warehouse) \times 3 meters \times 3 meters.

Determine Shipment Maneuvering Requirements

The maneuvering space required for shipping and receiving is the space necessary to enter and exit the truck and to move commodities between the truck and the shipment staging area or vice versa. The amount of space in the warehouse that you will need to exit and enter the truck depends on whether or not you have a leveling device, which is used to lower or raise the floor of the warehouse to facilitate the smooth movement of commodities from the truck to the floor of the warehouse or vice versa. *If there is a leveling device, each device is usually 3 meters deep \times 3 meters wide.*

Whether or not you use a leveling device, a certain amount of space will always be required to move the commodities from the truck to the receiving staging area. The required space for this area ultimately depends on the type of material handling equipment is used to move commodities from truck to floor and floor to truck. If manual material handling equipment is being used to move items from the truck to the floor (and vice versa), reserve at least 2.5 meters times (\times) the length of the designated shipping/receiving area (usually the length of the warehouse) for this activity. If, on the other hand, you are using powered material handling equipment, reserve at least 3.5 meters times (\times) the length of the designated shipping/receiving area.

Figure 2 represents the layout for the receiving/shipping activities of a typical warehouse. It depicts a warehouse where trucks dock at a 90° angle; it has four separate dock levelers. The diagram also shows an area for maneuvering commodities (shown outside the storage facility) and two staging areas (discussed in the next section). There is one staging area on either side of the warehouse; the two areas are separated by an access aisle.

Determine Shipment and Receiving Staging Requirements

Sometimes, warehouse managers allocate a specific space to process receipts and a separate specific space to stage issues. Past experience is often used to determine the required staging size needed for these areas.

Public sector warehouses in developing country settings (especially medical stores) are usually very different. In these settings, shipments are issued to customers much more frequently than supplies are received. Likewise, the size of the average receipt from a supplier is often many times

Figure 2. Typical layout for receiving/shipping activities

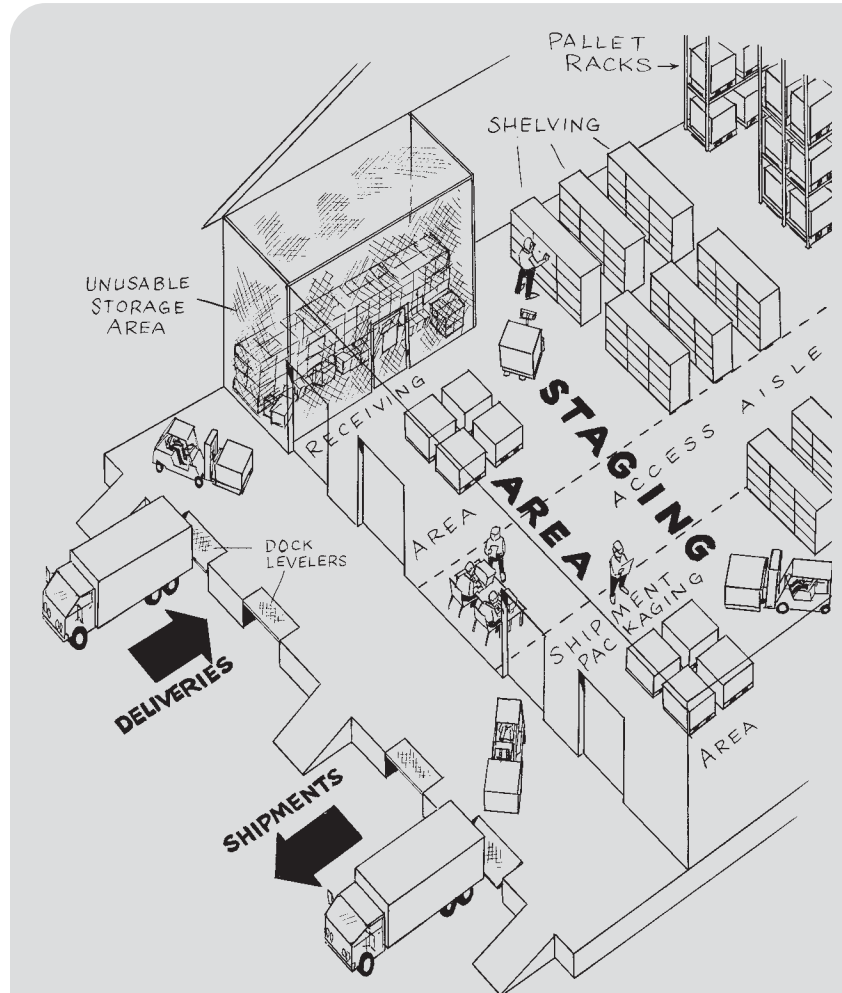

greater than the size of the average shipment issued to a customer. Because of the disparity between receipts and issues, you should have interchangeable shipment and receiving staging areas (i.e., there should only be one combined shipment/receiving staging area). It should be noted that this would prohibit you from establishing separate shipping and receiving areas on separate sides of a warehouse.

Determining the size of the receiving/shipment staging area can be the most difficult part of planning the layout of a warehouse. It is important to be as accurate as possible when you estimate the size of the area. If you allocate too little space, stock from arriving shipments will probably fill storage aisles before it can be put away. If you allocate too much space, you may not have enough room on the available racks to store all the commodities that require storage.

To develop an accurate estimate of space requirements for the staging area, the estimation process should take place during a *surge period*. For these guidelines, a surge period occurs when the largest known or expected carrier arrival is received on the same day as the largest known or expected shipments are being staged for customers.

It is assumed that during the surge period, the commodities received from a supplier must enter the warehouse (i.e., they cannot remain at customs or somewhere else on the warehouse grounds), and any required inspection of the commodities must be completed quickly. It also assumes that the shipments being staged for delivery to customers must be staged or delivered on that day.

Step 3: Estimate Shipping and Receiving Staging Requirements

The following three methods are available for estimating the space requirements for staging:

1. *Complete data estimation methodology*. You can use this methodology when complete data on receipts and issues are available for at least the past year (preferably more). The data must include enough information on each shipment received or issued to completely identify the commodities received or issued, the number of cartons received or issued, and the volume of these cartons.
2. *Partial data estimation methodology*. You can use this methodology when complete data on receipts/issues are not available, but data on overall amounts issued or received during the year are available or can be readily estimated for all medium- to high-turnover items. To use this method, estimate the dimensions for most of the cartons and the approximate number of individual receipts and issues that took place during the year. Have the estimates available.
3. *Data-less estimation methodology*. Use this estimation method when you must guess the space needs because you have little or no information available to make a decision.

Complete Data Estimation Methodology

When data are complete or nearly complete on shipments received and shipments issued, you can make a very accurate estimation of the staging space requirements. This method relies on detailed information being kept on shipment content lists. Information must be available for every receipt or issue, and must show (1) the date of receipt/issue; (2) the identity of commodities received/issued; (3) volume (width × length × height) of the packaging used (e.g., carton, bundle, wooden crate); (4) contents of each package (items per package); and (5) number of packages in the shipment.

1. When using this method, first gather all shipment lists for the past year (or two years, if available). Review the receipts to identify the date on which the largest shipment (or shipments), by volume, was received by the warehouse. After reviewing the receipts, review the issues to identify the date on which the largest shipment/shipments were issued by the warehouse, based on volume. Use the combination of the largest receipt(s) and largest issue(s) to simulate the largest surge that the warehouse can expect.

Note: If the size of the largest shipment and/or largest receipt is expected to grow significantly in the near future, incorporate this fact when you estimate the needs for the surge period.

2. For the second step, use the data from step one to calculate the total volume of the receipts/issues expected during the surge period. Table 2 shows how to calculate the total volume if you only have one receipt (containing three commodities) and one issue (containing two commodities) during the surge period. An actual exercise would probably include one (or perhaps two) receipts that contain numerous commodities and several issues (each containing many commodities).
3. After you determine the total volume in cubic meters of shipments received/issued during the surge period, you can estimate the number of pallets that will be required to hold the commodities, simultaneously, in the staging area. The number of pallets will be equal to the number of cubic meters, because each pallet typically holds about one cubic meter of goods. Thus, the area required to stage these commodities is equal to the number of pallets (given in square meters). It would be prudent to add a few extra square meters to the overall estimate of space required for staging; because not all pallets are exactly one square meter in size, and you cannot place them exactly adjacent.

Table 2: Sample Worksheet for Estimating Shipment Receiving and Staging Space Requirements: Complete Data Method

Type of Transaction	Date of Transaction	Commodity	Total Amount	Amount per Carton	Number of Cartons	Size of Carton	Cartons per One Cubic Meter	Number of One Cubic Meter Pallets Required
Receipt	4 October 2004	Amitriptyline Tablet, 25 mg	2,000,000	20,000	100	.5 m x .25 m x .25 m	32	4
Receipt	4 October 2004	Erythromycin, Tablet, 250 mg	5,000,000	25,000	200	.5 m x .5 m x .25 m	16	13
Receipt	4 October 2004	Chloramphenicol, Vial, 1 gm	10,000,000	25,000	400	.5 m x .5 m x .25 m	16	25
Issue	4 October 2004	Amitriptyline, Tablet, 25 mg	200,000	20,000	10	.5 m x .5 m x .5 m	8	2
Issue	4 October 2004	Erythromycin, Tablet, 250 mg	1,000,000	25,000	40	.5 m x .5 m x .25 m	16	3
Total	4 October 2004							47

Note: Number of one-meter pallets required must be rounded up to next highest number.

Using Partial Data Estimation Methodology

It is possible to estimate, with reasonable accuracy, the space requirements for staging if detailed information on receipt and issue shipment contents is not available but overall amounts of each (or most) commodity received and issued is known or can be estimated.

This method requires the following information:

- *Total numbers (given in tablets, pieces, vials, etc.) received and issued during the past year (or two, if possible) for most or all commodities kept in the warehouse during this period. It is especially important to include high-turnover items. You can probably ignore very low-inventory items.*
- *Capacity and dimensions of the standard packaging for each of these items (e.g., 50,000 tablets in a carton .5 meters × .5 meters × .25 meters). You can find these numbers on the current packaging used in the warehouse.*
- *Estimate of the total number of shipments received and the total number of shipments issued during the workdays in question. You can ask warehouse staff to obtain this information. Receipts should be infrequent enough that the total number during the past year can be quickly estimated. For issues, it might be easier to estimate the average number per workday or workweek and extrapolate to one work year.*

Based on the previously mentioned data, it is possible to estimate the volume of each commodity in the average receipt and issue. These volumes can be aggregated to produce the overall volume that would have to be staged on an average issuing day that happens to fall on the same day that an average-sized shipment is received. Table 3 shows how the overall volume was calculated in a case where the average receipt contained three commodities and the average number of issues, on a given day, was one (containing two commodities). An actual exercise would probably include one (or perhaps two) receipt containing numerous commodities and several issues (each containing many commodities).

Table 3: Sample Worksheet for Estimating Shipment Receiving and Staging Space Requirements: Partial Data Method

Type of Transaction	Commodity	Total Yearly Amount Received/ Issued	Average Number of Receipts/ Issues per Year	Average Amount in a Receipt/ Issue	Amount per Carton	Number of Cartons	Size of Carton	Cartons per One Cubic Meter	Number of One Cubic Meter Pallets Required
Receipt	Amitriptyline, Tablet, 25 mg	10,000,000	5	2,000,000	20,000	100	.5 m x .25 m x .25 m	32	4
Receipt	Erythromycin, Tablet, 250 mg	25,000,000	5	5,000,000	25,000	200	.5 m x .5 m x .25 m	16	13
Receipt	Chloramphenicol, Vial, 1 gm	30,000,000	3	10,000,000	25,000	400	.5 m x .5 m x .25 m	16	25
Issue	Amitriptyline, Tablet, 25 mg	8,000,000	40	200,000	20,000	10	.5 m x .5 m x .5 m	8	2
Issue	Erythromycin, Tablet, 250 mg	20,000,000	20	1,000,000	25,000	40	.5 m x .5 m x .25 m	16	3
Total									47

Note: Number of one-meter pallets required must be rounded up to next highest number.

After you calculate the total volume (in cubic meters), you can estimate the number of pallets that will be required to hold the commodities, simultaneously, in the staging area. The number of pallets will be equal to the number of cubic meters, because each pallet usually holds about one cubic meter of goods. Thus, the area required to stage these commodities will be equal to the number of pallets (given in square meters). It may be prudent for you to add a few extra square meters to the overall estimate of space required for staging, because not all pallets can be stacked perfectly or placed exactly adjacent to one another.

In most cases, the partial data method will produce a reasonable estimate of the space requirements for staging. Because the issue and receipt staging areas are interchangeable, most or all of the allocated space can accommodate an unusually large receipt and vice versa. Occasionally, however, you will encounter a situation in the warehouse when an unusually large receipt arrives on the same day that unusually large issues are being staged. If this situation seems likely, you may need to increase the estimated space requirements for staging by some percentage. In these examples, a 50 percent increase may be reasonable.

Using Data-less Estimation Methodology

In cases where the warehouse in question is a new facility and/or data on receipts/issues are not available, it will be necessary to guess how much of the warehouse to allocate to staging. In general, the warehouse staging area should take up at least 10 percent of the warehouse's total space but never more than 40 percent. You must estimate exactly how much space to allocate.

Estimating the amount of space to allocate in these situations will depend on how much control you have over the carrier arrivals (i.e., to what degree can the warehouse dictate exactly when a truck carrying incoming commodities can deliver its load?). In these cases, use the guidelines in table 4 to estimate space requirements.

Table 4: Estimation of Staging Space Requirements

Degree of Control of Arrivals	Percentage of Warehouse for Staging (%)
Complete control	10 to 20
Some control	20 to 30
No control	30 to 40

Note: It is important to maintain an aisle space somewhere within the shipment and receiving staging area at all times. This space provides access from the dock to other parts of the warehouse (most important, the storage area). The width of this aisle depends on whether traffic through it will be uni-directional (one-way) or bi-directional (two-way). Because commodities should be placed in the staging area from one end and removed from the other end, a uni-directional aisle should be sufficient. The width of this aisle should be about 2.4384 meters if manual material handling equipment is used and 3.6576 meters if motorized material handling equipment is used.

Consider Other Space Requirements Associated with Shipping and Receiving

The shipping and receiving activities (and most other warehouse activities) need a dispatching area, which is a section of the warehouse designated for processing information and dispatching personnel to fulfill various tasks (e.g., to unload, put, pick, or load items). This area usually has a number of tables set aside for microcomputers and associated equipment. Sometimes, the dispatching area is located in a walled office, although it is often located in an open area within the receiving/shipping section of the warehouse.

The dispatching section of the receiving/shipping area should only require an area approximately 2.5 meters × 3.5 meters.

In addition to the dispatching area, you may need to allocate a set amount of space to hold empty pallets. The number of empty pallets should only slightly exceed the number of empty rack locations. Consequently, *it should only be necessary to allocate an area 2.5 meters × 1.25 meters of the receiving/shipping area to hold empty pallets.*

Although it is not evaluated in this manual, in some warehouses, cross-docking is a major part of the receiving/issuing activity. If cross-docking is likely to become part of your requirements, you may need to estimate its space requirements and establish a separate area in the store for this purpose.

Summary of Space Requirements for Shipping and Receiving

The following summarizes the expected space requirements for shipping and receiving:

- *Truck docking.* If trucks dock at 90° angle, no space is required. Otherwise, a triangular area measuring 4.25 meters wide (at the entrance to the warehouse) × 3 meters × 3 meters will be required for each docking space.
- *Leveling for loading/unloading.* If leveling devices are used, each device will require an area approximately 3 meters deep × 3 meters wide.
- *Maneuvering for loading/unloading.* If manual material handling equipment is used, an area 2.5 meters deep by the width of the designated receiving/shipping area is required. If motorized material handling equipment is used, an area 3.5 meters deep by the width of the receiving/shipping area is required.
- *Staging.* The space required for staging can be anywhere from 10 to 40 percent of the entire warehouse. The earlier section provides methods for estimating staging space requirements.
- *Dispatching.* If the warehouse does not have a dedicated walled office to house the dispatcher and dispatching computer(s), an area 2.5 meters × 3.5 meters is usually required.
- *Storage for empty pallets.* An area 2.5 meters × 1.25 meters is usually required.

See figure 2 (shown earlier) for a layout of *shipping and receiving* activities in a fictional warehouse. In this example, there are four 90° docks; level, motorized material handling equipment is used on each dock. There are two staging areas (one for shipping and one for receiving); the dispatching area is located within the receiving/shipment staging area; and the maximum space requirement for the staging area is about 30 percent of the warehouse.

Step 4: Determine Space Requirements for an Ideal Layout for Storage and Retrieval

Estimating the space requirements and layout for storage and retrieval is the most difficult task in layout planning, and you must complete a number of separate activities:

- Define the commodities to be stored.
- Establish a material storage method for each commodity.
- Estimate the total volumetric requirements for each commodity.
- Identify physical warehouse constraints to actualizing a layout.
- Generate an ideal layout using selective pallet racks and bin shelving.

- Determine when and how to consider alternative layouts.
- Develop methodologies for storing commodities in a given layout.

Define the Commodities to Be Stored

With layout planning for storage/retrieval, the easiest task may be to define the commodities to be stored. This activity requires that you have a complete list of commodities that are either already in the warehouse or will be procured in the future. In some cases, predicting the types of products to be procured in the future may be a problem. Most mature health programs know what items are needed or will be needed.

Each commodity to be stored must be defined as follows:

- a. description of the commodity (a name should be unique to prevent confusion with other commodities; it is also necessary to define a stockkeeping unit [e.g., paracetamol 500 mg, bottle of 1,000 tablets])
- b. number of stockkeeping units per standard packing unit (e.g., 25 bottles per box)
- c. volumetric dimensions of standard packing unit (length × width × height)
- d. number of standard packing units per one cubic meter pallet.

For items that will only be stored on shelves (because the average level of stock is too small to require storage on pallet racks), only the product needs to be described (b, c, and d above are not needed).

Establish a Material Storage Method for Each Commodity

It is important to decide on a material storage method for each commodity. The two general methods are *fixed* and *fluid*. In fixed-location storage, each stockkeeping unit (SKU) is always stored in a specific location. No other SKU can be stored in that location even if the location is empty. In fluid-location storage, any SKU can be assigned to any free location.

It is possible to have both fixed and fluid systems operating in a warehouse simultaneously. In fact, this arrangement is sometimes preferable. A typical arrangement would call for most bulk supplies to be stored on pallets and loose items to be stored on shelves. Use a fixed-location system for items stored on shelves; use a fluid-location system for the pallets stored on the pallet racks.

The volume of the inventory of each item would dictate the storage method for that item. See table 5 to determine the storage method for a given commodity.

Table 5: Storage Methods by Commodity Type

Type of Commodity	Storage Method	Example Items
Low inventory items stored and issued in smaller packs	Fixed (entire stock kept on shelves)	Specialized medicines
Bulky items stored and issued in complete pallets	Fluid (entire stock kept on pallets)	Equipment
Items contained in large cartons stored on pallets but issued in smaller packs	Fixed (stock to be issued kept on shelves) and fluid (bulk stock kept on pallets)	Essential drugs that are issued by bottles or small packs; condoms

Other storage arrangements are also possible. For example, high-volume items that turn over quickly and have a issue pack size too large to fit on a shelf (e.g., Ringer’s lactate and other IV solutions) can be kept entirely in bulk storage on pallets using a fluid system of storage. In any event, it is important to identify the items to be stored on pallets

(using a fluid-location system) versus those to be stored on shelves (using a fixed-location system), because the storage method dictates the volume of stock to keep on hand.

Estimate the Total Volumetric Requirements for Each Commodity

After each commodity has been classified by storage method (fixed versus fluid), you can estimate the total volumetric storage requirements for each commodity.

For each item to be stored on shelves (i.e., fixed-location), it is usually appropriate to assign either one-half of one shelf or one shelf to store each item. Most warehouses will label the shelf according to the item or items stored on it. High turnover items should be assigned one entire shelf while low turnover items should be assigned one-half of one shelf. In some unusual cases, it may be necessary to assign more than one shelf because of a combination of high turnover and large order size (otherwise too much time will be spent replenishing the shelves with stock from bulk storage). You can estimate the total number of shelves required by adding the total number of shelves required for each commodity.

Estimating the total number of pallets required for bulk storage is more time consuming because it requires additional information. If data are available on average monthly issues and the average inventory level for each commodity is either known or has been set by some authority, it is easy to divide the average inventory level (given in cartons) by the number of cartons that can be stored on a single cubic meter pallet to estimate the number of pallets that will be required for each commodity. You can add the number of pallets required for each commodity to determine the total number of pallets to be stored in the warehouse. If desired, this total value can be multiplied by some factor representing the expected increase in volume due to increased warehouse issues over some period of time in the future (see table 6 for an example of a warehouse that holds only three items).

Table 6: Sample Worksheet for Estimating Bulk Storage Space Requirements Based on Complete Data

Commodity	Average Monthly Issues (includes expected increase)	Average or Desired Inventory Level (in months of stock)	Average or Desired Inventory Level	Number of Cartons	Size of Carton	Cartons per One Cubic Meter	Number of One Cubic Meter Pallets Required
Amitriptyline Tablet, 25 mg	1,500,000	6	9,000,000	450	.5 m x .25 m x .25 m	32	15
Erythromycin, Tablet, 250 mg	2,500,000	3	7,500,000	300	.5 m x .5 m x .25 m	16	19
Chloramphenicol, Vial, 1 gm	3,000,000	5	15,000,000	600	.5 m x .5 m x .25 m	16	38
Total							72

Note: Number of one-meter pallets required must be rounded up to the next highest number.

If average inventory levels cannot be determined because the monthly issues data are not available, you may need to guess how much of the warehouse to allocate for storage. The warehouse storage area can be from 60 to 90 percent of the warehouse's total space.

Estimating the amount of space to allocate in these situations depends on the size of the desired inventory level. The higher the desired inventory level, the more space will be required. Use the following guidelines (table 7) to estimate space requirements in these cases.

Table 7: To Estimate Space Requirements

Desired Inventory Level	Percentage of Total Warehouse Space Dedicated for Storage (%)
Low	60 to 70
Medium	70 to 80
High	80 to 90

Identify Physical Warehouse Constraints to Actualizing, Completing, and Finalizing Storage/Retrieval Layout

Some warehouses have fixed obstacles that constrain the placement of pallet racks and shelves. These objects can also affect the successful use of material handling equipment. It is, therefore, important for you to map the location of all fixed obstacles prior to completing a layout of racks and shelves for storing/retrieving commodities. Some examples of fixed obstacles include building support columns, stairwells, elevator shafts, sprinkler system apparatus, heating and air conditioning equipment, and possibly the overall size of the warehouse (if the storage/retrieval space requirements exceed the amount of available space).

Generate an Ideal Layout Using Selective Pallet Racks and Bin Shelving

After you determine the amount of shelving and number of racks required to store the warehouse commodities, you are ready to propose a layout based on available floor space for storage and any existing constraints. It is advisable to begin the storage layout planning phase by proposing a layout of selective (or standard) pallet racks and bin shelving. Selective pallet racks provide the greatest flexibility and is an acceptable storage capability for fluid locator systems. Bin shelving can be used to implement a fixed locator system.

Some or all the bin shelving is usually placed closest to the staging area. This allows personnel to quickly pick items to be packaged in the staging area. Because most of the stock on the bin shelves will be routinely replenished from stock kept on pallets in the selective pallet racking system, ideally, there should be easy access to both sides of the bin shelving (one side for picking and one side for replenishing).

It is advisable to separate the bin shelving into two sections, with an aisle between the shelving. The aisle will give more direct access to the pallet racks from the staging area. Figure 3 shows a typical layout for bin shelving.

Figure 3. Sample layout using selective pallet racks and bin shelving

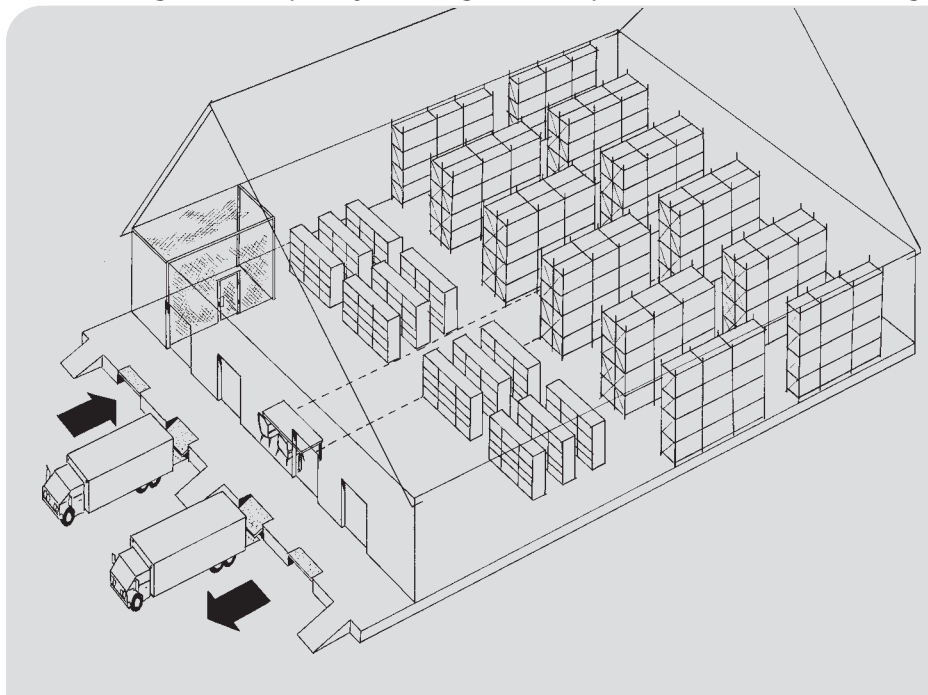

The placement of the selective pallet racks depends on the following factors:

- total number of pallet racks required to store the desired inventory
- ceiling height of the warehouse
- aisle space required by the material handling equipment.

The total number of selective pallet racks required is dictated by the average number of pallets to be stored. The aisles between the pallet racks must be wide enough to accommodate the selected material handling equipment (see the Racking and Material Handling Equipment chapter for typical widths of each type of equipment). The racks are normally placed in rows, with each row running from the front to the back of the warehouse. Cross aisles are often inserted in each row at 15 meter intervals.

If, after laying out the racks, there is significant free space in the storage area, that space should remain free. This will allow warehouse management to easily install additional racks if they are required at a future date. When the volume of inventory (and, consequently, the number of pallets) is not known precisely, selective pallet racks should be purchased to fill the area of the warehouse set aside for storage.

Step 5: Establish a Realistic Layout by Reconciling Space Requirements with Existing Constraints

As stated before, space is a primary resource that is common to all warehouses. The amount of space available and how the space is arranged are critical to operating an efficient warehouse. However, many existing warehouse facilities are faced with constraints that make warehouse space and layout design a challenge. Step 5 suggests ways to overcome existing warehousing constraints:

- When and how to consider alternative layouts
- Methodologies for storing commodities.

Determine When and How to Consider Alternative Layouts

It is possible that the warehouse will not be able to accommodate the ideal layout because of warehouse size limitations. In these cases, alternative layouts must be considered. You can manage this situation in many ways, without installing a new racking scheme.

A few methods might include—

- *Change the desired inventory level.* The average inventory level used to determine the volume requirements to store the commodities is based on a desired buffer stock. You may be able to reduce the desired buffer stock without jeopardizing the warehouse's ability to fill orders. Lowering the desired inventory level can have a dramatic affect on reducing space requirements.
- *Eliminate unnecessary aisle space.* If cross aisles were included in the ideal layout, you may be able to eliminate some or all of them. Eliminating *all* cross aisles may result in unacceptable productivity losses, so this should only be considered if other methods fail to free up adequate space.
- *Reduce space allocated for receiving/shipping.* This methodology, described earlier in this section, does not consider the possibility of storing pallets one on top of another. Though this is not ideal, in many cases, it is possible to store light-weight pallets on top of heavy-weight pallets without damaging the contents of the lower pallet. As much as half of all pallets can be stored one on top of the other, if necessary.

Note: It is not advisable to store medium- or heavy-weight pallets on top of each other.

- *Use different material handling equipment.* Some material handling equipment requires a larger turning radius than others. For example, an electric lift truck (sit-down) usually requires more aisle space to maneuver than an electric lift truck (stand-up). Switching from one type of material handling equipment to another may reduce aisle space requirements. (For more details on the turning radius of forklifts see the Racking and Material Handling Equipment chapter).

After you apply the previously mentioned methods to free up space, and there is still not enough room to accommodate the expected inventory, you may need to consider alternative racking systems for at least part of the warehouse (to store very slow-moving items).

Some possible alternatives to selective pallet racking are—

- double-deep pallet racks
- drive-in pallet racks
- pushback pallet racks.

Of these, only double-deep pallet racking is easy to implement and service. Double-deep pallet racking allows storage of two pallets from a single aisle, thus saving space (though it should be noted that aisle requirements may increase somewhat due to the special forklifts required). Double-deep pallet racking does not require the use of standardized pallets.

Each of these pallet racking systems has its benefits and its drawbacks. For more detailed information on each of these systems and many others, see the chapter on Racking and Material Handling Equipment.

Consider Methodologies for Storing Commodities in a Given Layout

After a layout has been adopted, it is advisable to adopt a plan for storing commodities on the racks and shelves. There are many methodologies for storing commodities.

ABC Methodology

In most warehouses, a large percentage of throughput is attributable to a small percentage of commodities. In most cases, about 75 percent of throughput is attributable to 15 percent of items (often called A items), another 15 percent of throughput is attributable to 15 percent of items (often called B items), and the remaining 10 percent of throughput is attributable to 70 percent of items (often called C items). ABC methodology states that A items should be located in an area of the warehouse that allows for the most productive material handling. This means that A items should be placed as close as possible to the staging area and should be easily accessible. All C items should be placed in the back of the store or in 2-deep pallet racks, if they are available.

One word of caution if you use ABC methodology: although A items should be placed closest to the staging area, they should not be placed so close together that congestion (from picking) results. All items should be spaced as evenly as possible.

Similarity Methodology

In some cases, items that are commonly shipped together should be stored near each other. For family planning programs, this might mean that contraceptives should be stored in a similar location within the warehouse. Any other groups of items that are shipped together should also be stored close together.

Size Methodology

The size methodology states that heavy and bulky items, which might include heavy furniture and equipment, should be stored close to the point of shipping to minimize

the effort and cost of handling them. It also suggests that these items should be stored as close to the floor as possible.

Product Characteristic Methodology

Some commodities have certain characteristics that dictate how and where they should be stored within the warehouse. Temperature is one of the most important of these characteristics. In tropical environments, certain medicines degrade under hot conditions. For this reason, these medicines should be placed in either a cold room or temperature-controlled area of the warehouse. Each commodity should be analyzed closely to determine its appropriate placement.

It may also be desirable to place either high-value or controlled substances in a similar location within the warehouse. These items may require increased security measures, such as isolated storage.

In summary, any number of the storage methodologies can and should be combined to improve the productivity of the warehouse. You must give serious thought to selecting the optimal combination for the greatest warehouse efficiency.

Step 6: Determine Space Requirements and Ideal Layout for Storing Unusable Items

When planning the space requirements for storing unusable commodities, it is important to understand that you may have more unusable commodities than you expect. The amount of space depends on the policy for removal/disposal and whether unusable items can be safely kept outside the warehouse. For this manual, it is assumed that all unusable pharmaceutical or medical supplies must be kept in a special section of the warehouse until you can determine their final disposition; therefore, you need to designate this type of section for the warehouse.

Estimating space requirements for items that are not usable is directly related to the wastage rate at the warehousing facility. Wastage can occur from expiration or damage (i.e., any action that results in commodities unsafe to consume). Data on wastage is normally maintained in the losses/adjustments column of stock records or, if automaton is used, in a table that contains losses and adjustments information.

If you have data on wastage and you think it is accurate, it is possible to determine when commodities were wasted and temporarily stored at the warehouse during the past year or two years. If information on removal of the unusable items is also available, you may be able to determine the length of time these items remained in the warehouse before removal. You can then construct a simple table with five columns (name of commodity, amount, estimated volume, date of wastage, and date of removal).

From this data, you can determine the maximum volume of unusable items kept in the warehouse at any one time by sorting the table on date of wastage and then plotting each row of the table (i.e., batch of unusable items) on a chart (resembling a Gantt chart). The chart should show clearly the batches of unusable items that resided in the warehouse at the same time. The sum of the volumes of these batches represents the maximum volume of unusable items that can be expected to be stored in the warehouse at any given time.

If data on losses/adjustments and removal of unusable items do not exist or are unreliable, you will need to rely on the memory of warehouse staff to estimate the maximum volume of unusable items at any one time. If warehouse staff explain that the only significant wastage occurs during physical inventory counts, it may be possible to use this as the basis for the maximum volume. Note that this assumes that any commodities found expired

or damaged during the physical inventory were removed from the warehouse before the next physical inventory account. If this is not true, you will need to estimate how much of the wasted stock remains in the warehouse and how long it has been there.

In some warehouses, you may also need to make special arrangements to hold the following items if they cannot be stored offsite:

- trash—including empty cartons, binding materials, broken pallets, and packing materials
- broken or unusable equipment and furniture.

You must consider space requirements for trash, because trash can result in congestion and loss of productivity. The most significant, and, in many cases, the only significant trash is corrugated box material. For these guidelines, it is assumed that all but the largest corrugated boxes received from suppliers are reused to package shipments to customers, and they are used at roughly the same rate as they are received. However, it is possible that large corrugated boxes that are received will accumulate and take up space; it is unlikely that they will be used for repackaging. These large boxes can take up a significant amount of space. However, in most cases, a 1 meter × 1 meter section should be large enough to hold a large number of broken-down corrugated boxes.

Racking Systems and Material Handling Equipment

Overview

A warehouse is more than just a building for storage. In addition to housing goods as efficiently as possible, warehousing facilities must serve many purposes. Warehouses are designed and built for storing (1) raw materials, and finished or partly finished goods; and/or (2) material that will be shipped out of the warehouse or divided into batches and distributed.

Today, due in part to product types and high customer demands, storage facilities must be able to accommodate the items above, and also provide rapid, easy movement of supplies from the product storage area to the shipping docks and beyond. Many warehouses must distribute products to regional or district warehouses, and even down to service delivery points (SDP). Good planning is needed to ensure the efficient use of space, and handling and storage of commodities, to meet and achieve warehouse objectives; and to complete essential tasks. These efforts can improve warehouse efficiency and lower overall operating expenses.

Warehousing is viewed very differently now than it was 20 years or more ago. In the past, a warehouse was a place to store goods and was not part of a distribution logistics network; little or no attention was given to material handling equipment. Today, however, warehouse managers are responsible for all aspects of materials management, including a total systems approach to plan, acquire, store, move, and control materials; which completes the cycle of information and material flow. To complete these essential warehouse operations, materials must be handled in a well-organized and effective manner. To help comply with these responsibilities, and to complete both the information and material cycle, appropriate warehouse equipment is needed, such as racking systems and material handling tools.

Warehouse managers are faced with challenges and potential problems related to products, including warehouse design, making it necessary to anticipate change and to be prepared to adapt today's systems, at a reasonable cost. Warehouse equipment is usually selected using the following criteria:

- degree of equipment flexibility desired for different uses
- type of warehouse building (size, design, and desired physical movement of products)
- type of products and load sizes (largest and smallest) stored in the facility
- total volume (inventory levels) to be handled by the facility
- size of orders and the time it takes to fill the orders
- human resources (number of facility employees, skill level, training needs, and language barriers)
- equipment availability in facility location (new, used, and spare parts)
- equipment cost (new, used, and replacement equipment).

This chapter addresses these criteria as they relate to the different types of pallet racking systems. When you present the different types of racking systems to co-workers or managers, remember that as pallet racks developed and their designs progressed, these changes went

hand-in-hand with the development of forklift equipment. As height and load capacity of lift trucks changed, rack sizes also changed. Throughout this chapter, the text and examples explain the parallel development and how they need to be incorporated when you discuss and design a fully functioning warehousing operation.

What Is a Material Handling System?

A material handling system has been described many different ways. For this chapter and the purpose of these guidelines, a material handling system is a combination of methods, space, labor, and equipment that functions under a unique set of operating conditions and objectives. The warehouse environment demands that a facility be fully controlled, including the operations, information, and material flow; and the tasks that people perform. The material handling system *unifies* warehouse operations, and it is a link that adds value to both the customer and facility operations.

In simple terms, material handling is divided into two main areas:

- *Physical flow (material)*: how materials within the system are handled, moved, and stored.
- *Information flow*: directly related to how materials are controlled and monitored.

Both the physical and information flow can be conducted by manual, mechanical, or automated systems. Either type of flow (physical or information) requires three components to function properly: space, labor, and equipment.

The main justification for storage equipment (pallet racks, shelving/bins, etc.) is to increase how space is used or to make optimum use of the building space. In the U.S., space is usually measured in cubic feet of occupancy; however, for this section and the other sections, we use meters or cubic meters. Whatever type of measurement is used, incorrectly calculated storage space contributes to poor utilization and can result in space shortages and increased warehouse cost. Conversely, creating a more compact area to perform warehouse operations usually reduces picking and traveling time.

Racking and Shelving Systems

Racks

In addition to making optimum use of space, racking and shelving systems also provide simplicity and organization of materials and warehouse operations. Most pallet type racks have two parts: upright frames and horizontal beams. Racks are usually easy to assemble and simple to use; they are the foundation of any small- and large-scale storage facility. Pallet racks are strong and can handle high-traffic industrial products, as well as small, slow-moving, lightweight products, such as most essential drugs and HIV/AIDS products (antiretroviral drugs, HIV test kits, etc.), and reproductive health commodities.

Today, steel pallet racks consist of storage systems that can be single-leveled or multi-leveled structures, and used to store single items or palletized loads (and other types of containers). Additionally, rack structures provide access for order-picking case lots or individual pallets.

Shelving

Steel shelving is a storage system usually designed to store un-palletized loads (small individual cartons or loose items) placed on a manual or automated retrieval mechanism. Steel shelving consists of basic sections that can be accessed from the floor and used to

store a variety of products. In highly productive facilities, it is not uncommon to see both the conveyor and shelving used together in certain systems, such as order-picking operations.

Rack Planning Considerations

Any major investment relating to a warehouse facility should be accompanied by a long-range strategic plan. Before presenting information on the different types of rack systems, managers need to review a number of important considerations and parameters.

Issues to consider before purchasing rack equipment include—

- volume (size and weight of loads)
- pallets/containers (type, condition, dimensions, and weight)
- equipment clearance (standard height of equipment and height of equipment extensions, such as forklifts and load heights)
- building dimensions
- warehouse floors.

Volume

Inventory volume should be considered first before purchasing a rack system. For many warehouse facilities and their products, inventory levels are constantly changing. Products may be added or deducted from the product mix; product sizes and weights may change. Fluctuating inventories or the inventory mix can create many challenges for the warehouse manager. A recent change in policy, for example, may require a facility to carry new products (HIV/AIDS commodities), which can suddenly affect product mix and inventory volume levels. Additionally, seasonal changes (the rainy season may require more malaria intervention products) may also have an impact on warehouse products and its operations.

Before selecting any type of storage equipment, managers need to conduct a thorough analysis for long-term planning to determine the average size and weight of the loads that the facility will handle. Also, included in this planning are the largest and smallest possible load sizes. The actual handling and equipment characteristics will vary; some equipment may be used to handle loads as large as 1361 kilograms and as small as 68 (or smaller) kilograms. The facility's products and volume will help guide and determine the type of racks and/or shelves needed. Racks should be selected to prevent overloading, which can cause warehouse staff injuries, structural rack fractures, and product damage. Human safety and product safety are the highest priority during and after the planning process. Facility managers are responsible for regularly conducting facility safety reviews and safety reviews for internal equipment.

Pallets/Containers

Another issue to consider before purchasing storage equipment is the pallet or type of container that the facility will use for its products and warehouse operations. Facility managers need to consider asking relevant questions that include—

- Does the facility have wooden pallets and, if so, what are the dimensions?
- Does the facility have different types of pallets (wood, metal pallets, fiberglass, cardboard containers with wooden pallets attached), or does the facility have steel containers?

- What other types of pallets or containers will be used in day-to-day warehouse operations?

No matter what type of pallet or container a facility is using, warehouse managers should know the dimensions and weights before the racking equipment is purchased.

Equipment Clearance (Dimensions)

Warehouse managers need to completely review the load and equipment clearance requirements. Load and equipment clearances should address or reference height and width for aisles, doors, loading docks, ceilings, and any external areas that equipment and products will pass through. The clearance review needs to take place both inside and outside the facility. Again, throughout the planning process, managers need to ask and review fundamental equipment questions, which include the following:

- Does the face of the rack or load overhang the pallet rack by 0.0762 meters in the front and/or the rear?
 - Using standardized pallets, the rack depth over the shelf load beams is usually 0.1524 meters less than the pallet length, which results in 0.0762 meters of overhang of the pallet on the shelf beams (0.0762 meters of overhang on each end of the shelf equals 0.1524 meters of overhang to prevent damage to the rack structure itself and to make it easier and faster to place the pallet on the shelf).
- If the overhang is 0.0762 meters, what effect will that have on the aisle width (that could mean a loss of 0.1524 meters in the cross aisle dimension)?
- What effect will the loss of 0.1524 meters have on maneuverability or desired storage space?
- When considering the clearance needed for fire protection (sprinklers, etc.), are there mandatory legal fire protocols that must be followed (height from ceiling, number of sprinklers/per cubic foot, and placement and number of fire extinguishers)? Extinguishers placed on facility support columns could reduce aisle or floor space.
- Have all the various pieces of equipment used within the facility area (inside and outside) been checked for dimensions and the data collected for analysis?

Building Dimensions

The overall building dimensions should match or have the capacity for specific equipment and other space needed to carry out the required warehouse operations. The more research and groundwork completed, and essential questions warehouse managers ask before purchasing equipment, the more efficiently a racking system will work and ultimately sustain the needs of the facility. The warehouse manager will also need to strategically address additional questions and challenges:

- What confrontations, if any, do building columns present, and do doorways have the necessary clearance requirements for safe passage of both equipment and people?
- Do doorways and loading/unloading ramps pose needless dangers to people, equipment, and products?

Warehouse Floors

Together, the facility management and a qualified engineer need to thoroughly check the warehouse floor. The floor must be able to carry product loads, as well as support rack post and forklift equipment, without causing short- and long-term damage to the floor. A special floor review needs to take place in older warehouses. In most situations, these floors were in place long before anyone thought about putting in a racking system; therefore, when a racking system is installed that is not part of the original design, the warehouse usually develops multiple floor problems. Warehouse floors, for example, that do not meet stress and strength requirements may fail due to pressure from the rack base plate or diagonal tension, or the weight of just the forklift. If the warehouse floors do not meet stress specifications, damage can also result from day-to-day material handling traffic (forklift, etc.).

There are many key requirements to review and keep in mind when you analyze your current floor layout or when you consider adding an addition or constructing a new floor. The warehouse floor must meet certain specifications. Some of the key requirements to review include—

- floor surface (surface material, depth of material, sub-surface material, etc.)
- door openings (surface material around loading/unloading dock doors, warehouse exit doors, etc.)
- building column locations
- lift equipment aisle-width requirements
- placement of overhead lighting
- fire control (fire extinguishers, sprinklers)
- loading and floor stacking of material
- cross-aisle requirements
- overall length of rack rows (possible effects on floor surface).
- quantity (approximate) of load units to be stored in the racking system.

As mentioned earlier, if rack equipment is to be configured on existing floors, in addition to the earlier list, you must thoroughly inspect the existing cement or floor surface material, as well as the material and supporting structures beneath the surface. There are many ways that an existing warehouse floor may not meet weight and overall durability requirements. Some general ways a floor may fail includes compression of the concrete, shear or tension and, sub-base failure.

To fully maximize the level of safety for the facility's staff and its products, as well as the facility's functionality and financial cost, a qualified engineer must check the floor or slab design and the load (weight) of the rack post on the floor. A thorough floor analysis can prevent sustained floor damage from occurring, as well as protect people and products.

General Categories (Types) of Rack Systems

The most common large pallet storage systems include—

- selective pallet rack
- double-deep selective pallet rack
- drive-in racks (2, 3, and 4 deep)
- drive-through racks (2, 3, and 4 deep)
- push back racks (2, 3, and 4 deep)
- gravity flow pallet rack (live pallet storage) (2, 3+ deep).

The most common small product and non-pallet load arrangements include—

- dynamic small product storage/picking systems
 - carousels (horizontal and vertical)
- static small product storage systems
 - bin shelving systems
 - modular drawer storage
 - gravity flow racks (carton flow racks).

As mentioned earlier, warehouse managers must focus on load characteristics and lift equipment when selecting a functional racking system. Additionally, pallet racks require more square meters per pallet than bulk storage areas; however, racks allow access to a specific pallet or individual pallets (loads).

The most efficient way to assess pallet racking alternatives is to consider using two dimensions: selectivity and storage density or space utilization. Selectivity is assessed by fully loaded installation and determining the percentage of loads directly accessible from an aisle. Having all loads available on an aisle can be a great advantage for an organization, providing versatility as well as being cost effective.

Storage density or space utilization measures how effectively storage volume can be used. In a selective rack system, for example, each item would require aisle space, which would result in fewer items stored in a given volume (area or space). Depending on the product and the facility's needs, some warehouse operations solve this problem by using denser rack solutions. One example of a denser rack system is loads that can be stored two or more positions deep within the same row. Using double-deep and pushback systems, aisle space for storage and retrieval can be divided between several loads, thus reducing the required amount of storage space per load. However, as you will see while reviewing the different types of racking systems, the type or types of racks warehouse managers select is driven by a number of key variables, not just the facility's products.

Large Products Storage Systems

Selective Pallet Rack

Selective pallet racks are perhaps the most commonly used pallet storage equipment in the world.

Selective pallet racks, also known as single-deep racks, are a storage module one pallet deep. Each pallet is individually accessible from the aisle, and single rows can be placed against walls to utilize floor space more efficiently. The selective pallet rack is considered one of the more flexible type racking systems because pallets can be stored, retrieved, or picked without handling other pallets. This type of rack system consists of a simple construction of metal upright frames and a pair of load beams for each shelf elevation (see figure 4).

It is important for warehouse managers to remember that the selective rack configuration places all loads on an aisle. In addition, the pallet and the unit load, including weight and overall dimensions, lift equipment, and building; direct which type of rack design is best suited for an individual facility. By establishing the storage rack dimensions you can correctly determine a warehouse layout. It is of primary importance that you determine the type of lift truck equipment that will be used for rack storage (the different types of lift equipment is discussed in the following section).

Rack Bay

At this point in the discussion, it is important to talk about rack bays. The basic fundamental building block of any pallet rack system is a *bay* (see figure 5). A rack bay is usually a designated area in a certain section of a storage area, which is defined by markings such as warehouse columns, posts, or floor.

Similar to building bays, which include the distance between walls to building columns, a rack bay is the space between upright frames or rack supporting columns. A rack bay is the space between upright frames or the rack supporting columns. A rack bay may consist of one or more shelves high, and comprised of horizontal bars (beams) and vertical members (frames) that suspend the horizontal members off the warehouse floor. The connection of two or more rack bays in length represents a row of racks.

Selective Pallet Rack Parts and Materials (metal compounds)

In most single deep selective pallet racking systems, construction consists of simple metal uprights and cross-members that provide immediate access to each load stored. When a pallet space is created by the removal of a load, a pallet opening is immediately available in single deep racking systems. In a selective rack system, rack frames consist of front and rear column sections that are fixed firmly together by horizontal braces and diagonal struts. The struts and braces are important because they give the frame

Figure 4. Selective pallet rack

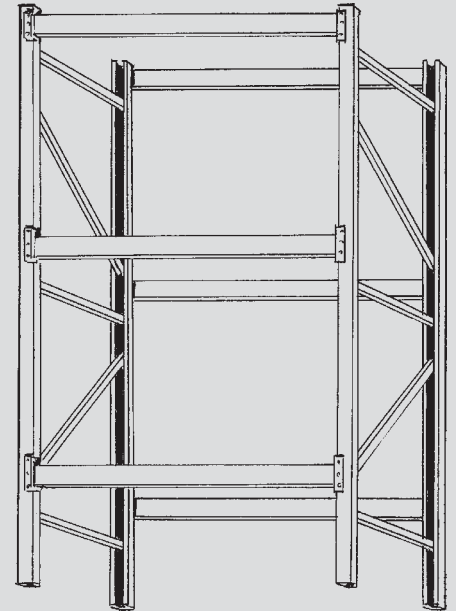
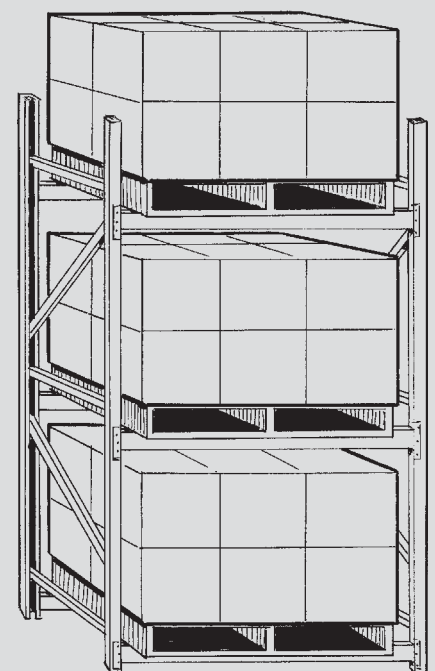
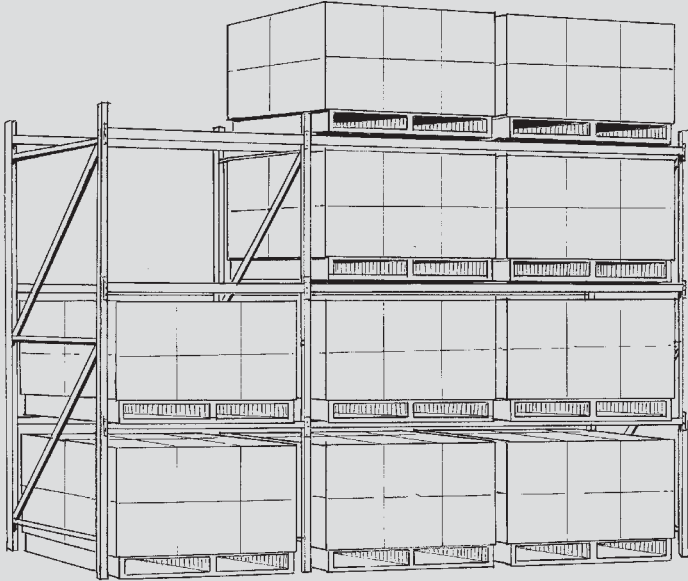

Figure 5. Single bay with pallets



assembly strength and rigidity. The rack braces transfer the horizontally oriented forces between the front and rear column sections, and the rack struts transfer the vertically oriented forces between columns. Of course, the greater the number of struts and

Figure 6. One row of connecting racks (2 bays) with 3 multi-shelves



braces on the rack structure itself, the more overall rack stability and long-term constancy the structure will provide.

When constructing a selective rack system, loads may be of varying heights and widths. However, no matter what height or width the racks are designed to accommodate, metallurgical compounds should be consistent. Currently, the most common column materials consist of cold-rolled formed sections (steel) of a rectangular or square shape.

Just as important are the horizontal metallurgical compounds. The horizontal load-bearing beams are also constructed of cold-rolled steel members or hot-rolled structural shapes. In addition, because the beam must span a bay and must be able to be attached to the vertical columns, each end of the beam has an end plate or fitting (connector) welded or bolted to it to facilitate the attachment.

Figure 7. Common rack beam sections (rolled-formed left, structural right)

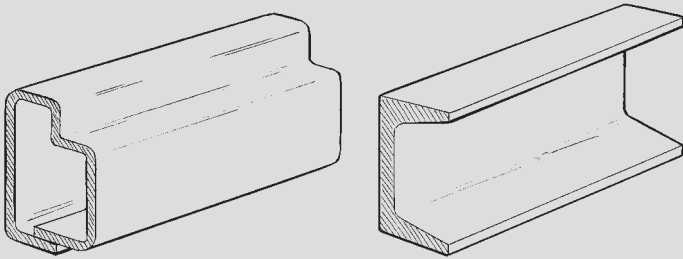

For various reasons (economic, engineering capacity, efficiency, safety, etc.), rack manufactures have standardized their column and beam section shapes. For reasons mentioned earlier, and because height usually determines beam capacity, most roll-formed beams are box-like structures, which efficiently use material (see figure 7).

For columns to be metallurgically effective and efficient, and to avoid bending, a rectangular or square shape is a safer and more practical design (see figure 8).

Figure 8. Common rack column sections

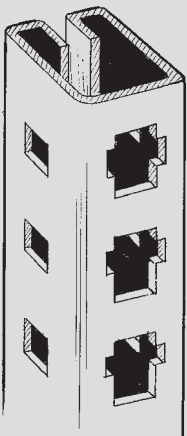
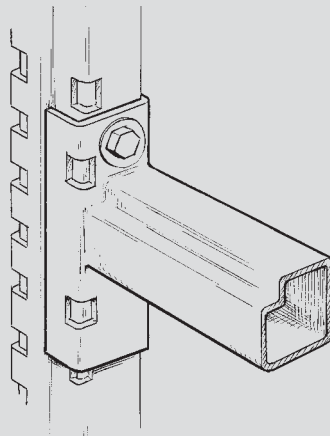

Figure 9. Rack column section with teardrop connector



Rigid beam-to-column connections are a primary factor for ensuring the safety and long-term service life of a rack system. A racking system's rigidity depends on very rigid beam-to-column connections. The two common types of connections are teardrop (also called keystone-shaped keyhole [see figure 9]) and bolted connections. Bolted connections require more time to install and, to be effective, they must have periodic inspections and the fasteners must be tightened.

Other types of rack connections are available that have been designed for roll-formed systems. These connections also ensure connection rigidity and are very easy to install and reconfigure. In addition, to ensure continued safety when using connections of any type, facility managers need to ensure that periodic safety inspections are carried out.

Examples of a Rack Bay and CounterBalanced Lift Truck Requirements

Again, a bay is the fundamental building block of any pallet rack system. Most selective rack systems have bays that are two pallet widths wide (see figure 10). However, a bay can consist of a single pallet, or two pallets or more (product volume and weight is the determining factor); and any given rack bay can be one or more shelves high.

As previously discussed in the Equipment Clearance section, when handling standard U.S. pallets (1.219 meters deep \times 1.016 meters wide), the rack depth over the shelf load beams is usually 0.1524 meters less than the pallet stringer length. These dimensions result in 0.0762 meters of front and rear overhang of the pallet over the shelf beams. If 0.0762 meters of overhang is desired, the required frame depth is the depth of the pallet minus the total overhang allowance of 0.1524 meters. Thus, a 1.2192-meter deep pallet, for example, would require a 1.0668-meter deep frame.

The number of shelves that can be used per rack bay is determined by the lifting height of the lift truck and warehouse ceiling height. Most standard beam sections can handle two pallet loads (side-by-side) that range from 680.3886 to 1587.5733 kilograms each. Two 1.016 meter wide pallets may require a pair of 2.3368-meters long beams if 0.1016 meters is allowed on each side and between the pallets.

It is very important that you determine the type of lift truck equipment that will be used in the warehouse before rack construction is started. The most common types of lift equipment include the following (material handling equipment will be addressed in detail in the following section):

- counterbalanced (wide-aisle)
- reach-type (up-and-over)
- double-deep equipment
- straddle trucks (narrow-aisle).

Figure 10. Selective pallet rack bay with two pallets

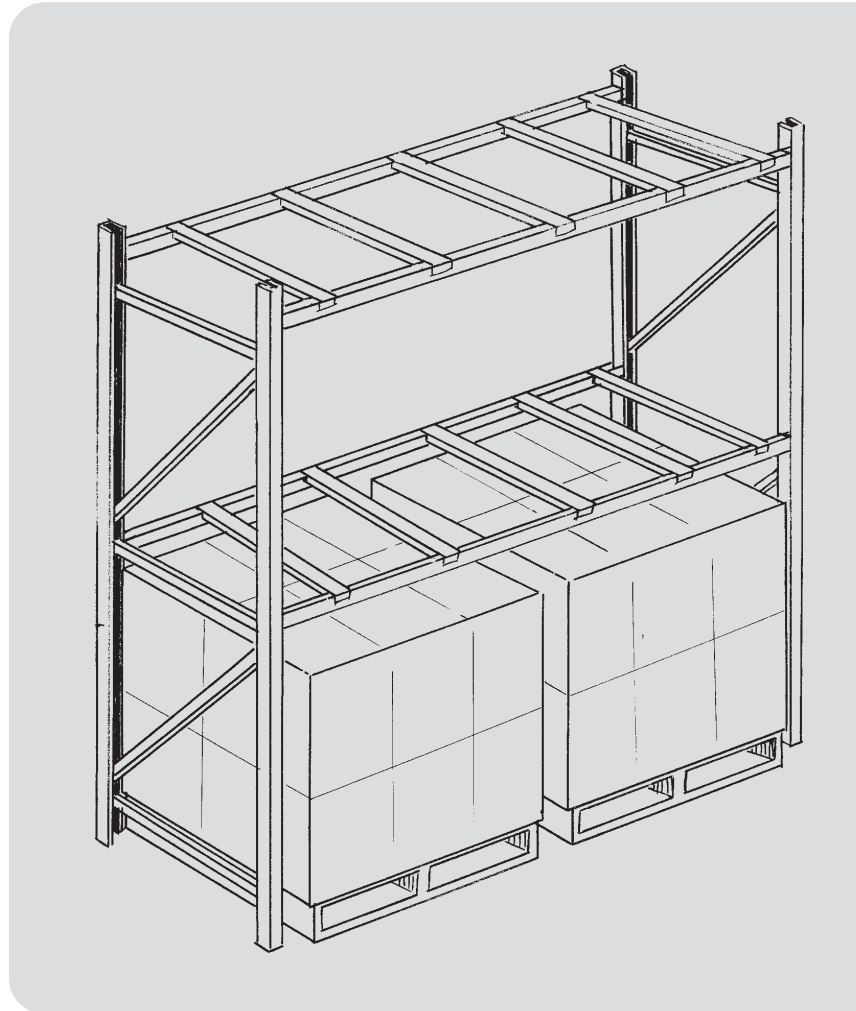
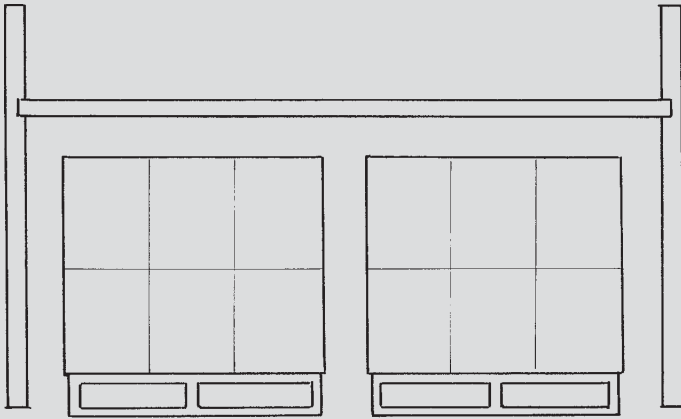

Figure 11. General pallet rack clearance requirements

Each type of lift truck has different characteristics that must be considered in determining appropriate operational clearances during the rack design process. When operating counterbalanced lift trucks, allow at least 0.016 meters between upright frame columns and the load, and at least 0.016 inches between the loads. Additionally, you should allow at least 0.016 meters of operational clearance from the top of the load to the underside of the upper rack shelf (see figure 11).

However, most straddle-type lift trucks require a minimum of 0.1397 meters between the upright frame

column and outboard side of the pallet stringer. The extra clearance (0.1397 meters) provides operational space for a 0.1016-meter wide straddle leg, which is part of this type of lift truck. Therefore, the straddle truck's legs operate below the pallet wing or overhanging face boards and between the pallet stringer and upright column (see figure 12).

As mentioned, the height of the storage rack must match that of the maximum lift height of any lift truck equipment. Therefore, when positioning a 0.1524 meter-high pallet, it is important for the top shelf to be at least 0.1524 meters less than the maximum lifting height of the truck. This information may seem basic or even intuitive to most warehouse managers and staff; however, you must determine and apply this information to provide an economical, practical, and workable storage rack system.

The number of shelves that can be used per rack bay is determined by several key factors: (1) the lifting height of the lift equipment, (2) allowable ceiling height, and (3) required load capacities to determine the required supporting capacity of the upright frame for one rack bay.

Double-deep Selective Pallet Racks

One way to reduce the number of aisles in a warehouse is to implement a rack system designed for two-deep storage. Double-deep pallet racks are selective racks that can

accommodate two-pallet positions deep (see figure 13).

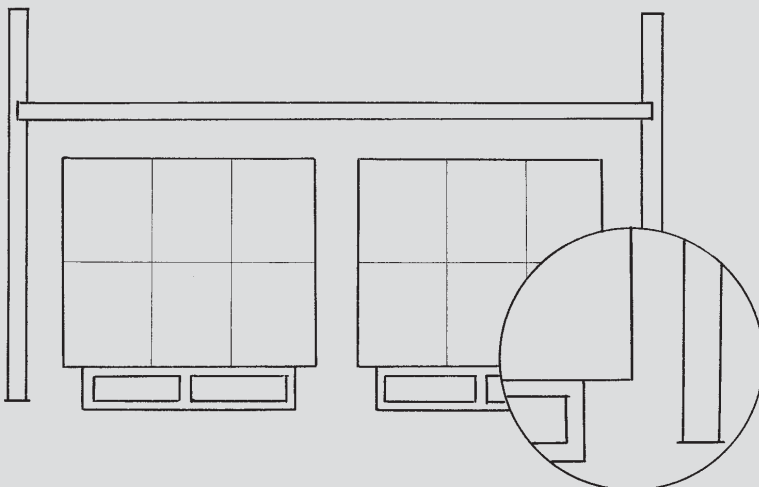
Figure 12. Pallet rack clearance for straddle-type lift trucks

These types of racking systems are typically used when the storage requirement for a stock keeping unit (SKU) is five pallets or greater and when the product is received and picked frequently, usually in multiples of two pallets.

The double-deep pallet rack configuration is identical to that of the selective rack setup; however, each bay is two-load depths deep; to pick up the load furthest from the aisle, the load on the

aisle must be removed. Because pallets are stored two deep, in many cases, a double reach forklift is required for storage and retrieval. Again, one advantage to using this type of racking system is that fewer aisles are needed within the warehouse facility. It is important to note that this system uses a storage retrieval procedure called *last-in, first-out*, which may not be appropriate for certain types of commodities, such as essential drugs, HIV/AIDS, and reproductive health products. Most health commodities require procedures for safe storage that maximize their shelf life and make them readily available for distribution. Thus, it is important that you choose rack systems that can be continuously examined, and that you ensure the *first-to-expire, first-out (FIFO)* procedures are followed.

Drive-in/Drive-through Pallet Rack Systems

The drive-in/drive-through rack system is usually considered an expansion of the double-deep racking concept. Thus, this type of racking system can have bays of three or more loads deep and only one pallet wide, and store two or more pallets high (see figure 14).

Drive-in racks are designed for bulk storage of palletized loads. As in the double-deep racks, only the pallets facing the aisle provide selectivity of the desired contents. Obviously, their configuration is not the same as the standard selective rack system. Rack bays are only one pallet wide, with two or more pallets deep and multiple pallets high. In this system, the pallets *rest* on support rails, which can be configured to forklift specifications. These configurations vary from manufacturer to manufacturer. Facility managers need to research the different types available, and make the selection that matches your facility's needs and specifications.

From a technical perspective, drive-in racks are designed so the lift trucks can *drive in* the rack from the aisle and between the rack columns and pallet support rails. When placing and accessing loads (pallets), the lift truck must enter the structure so that the load beams do not span across the bay in the lift truck's path. The pallets straddle load beams left-to-right (perpendicular to the aisle). Thus, the lift truck within this type of system must be operated in a slow and careful manner.

These racks allow products with poor stackability to be stored vertically in deep storage lanes, and each pallet is supported by a narrow shelf, so it's important to use good pallets. Overhang of products must be limited to reduce the width of the shelf. Depending on the ability of the lift truck driver, placing pallets on these types of structures may be more difficult than on the standard selective racks. Utilizing a drive-in rack system, managers must realize that it functions under first-in, last-out operations.

Figure 13. Double-deep rack with double-deep fork lift

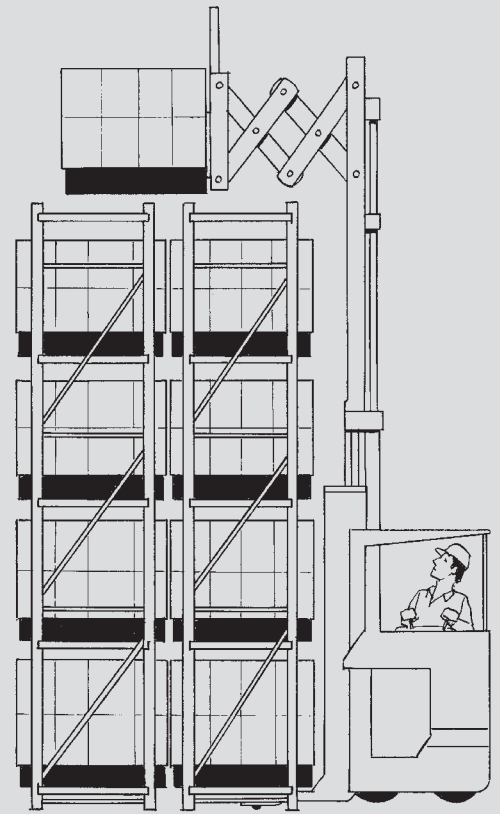

Figure 14. Drive-in rack three-deep

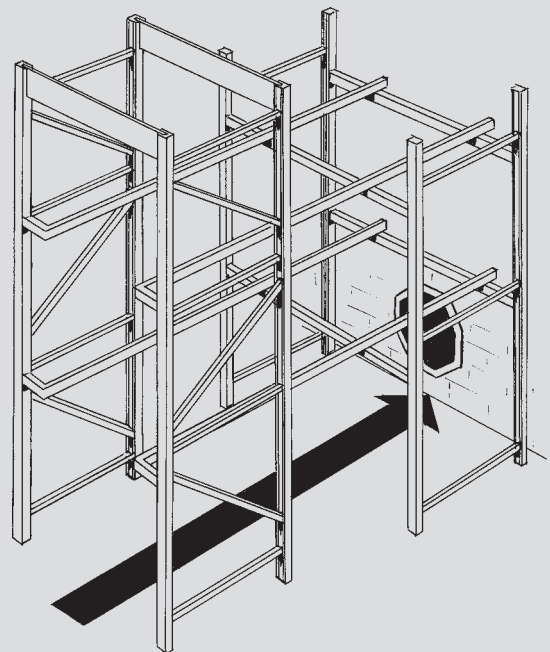
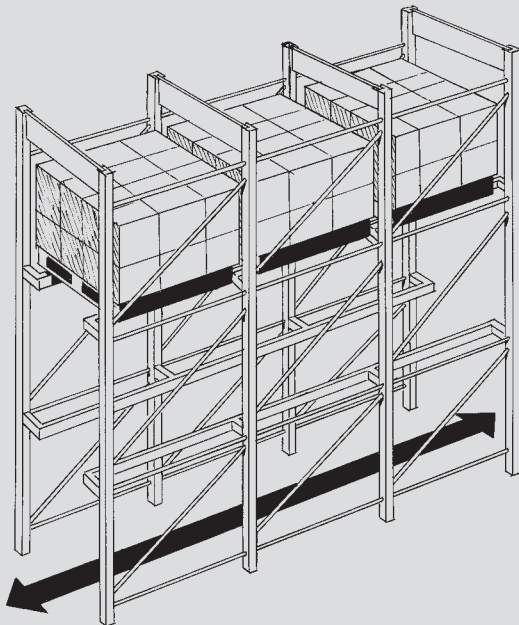

Figure 15. Drive-through rack three deep

Drive-through racks are simply a drive-in rack that is accessible from both sides of the rack (see figure 15). The rack beams have been removed to allow the forklift to drive through the rack structure. This type of system is used for staging loads in a flow-through pattern—a pallet is loaded at one end and retrieved at the other end. It is possible for drive-through to provide FEFO (or first-in, first-out) storage.

Again, both drive-in and drive-through racks serve as very dense storage configurations. For this type of system to use space efficiently, the system utilization must be high. In addition, drive-in rack systems are best used in operations that store a large volume of similar products. If this were not the case, drive-in rack systems could not be used to their maximum efficiency. Therefore, the rack configuration chosen must be the right one for the type of product movement throughout the warehouse.

Both the drive-in and drive-through rack systems require the same basic information that is required for selective

pallet racks. However, due to a more complex design, more specific data is required relating to the type of lift truck that is needed to perform warehouse operations.

Before purchasing a forklift for this type of rack system, managers must keep some key issues in mind, including—

- the bay opening and first shelf elevation must provide enough space for the lift truck and pallet load to enter the rack opening
- forklift body width and height
- width and elevation of overhead guard
- forklift hose reel location
- width and collapsed height of the forklift mast
- lift height of forks.

A proper rack system of this type can be designed only after these specifications are known and analyzed.

Push Back Racks

The push back rack system is another high-density storage system. Push back racks provide a last-in, first-out storage retrieval system. This system uses a rail-guide carrier for each pallet load that is stored and retrieved (see figure 16).

As you can see in figure 16, in this type of racking system, pallets are placed on carts on inclined rails. As a load is placed in storage, the lift truck pushes the load and the other loads back into the subsequent loads. Each storage lane has its own set of carts, which can operate independently. When all the loads are pushed back in their respective

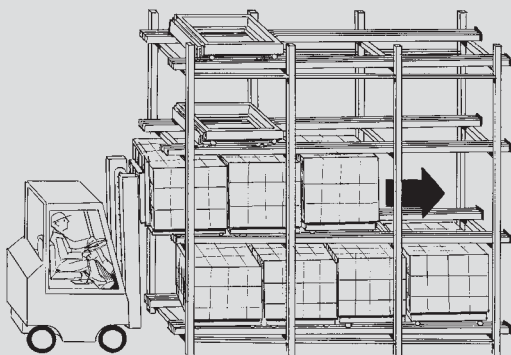
Figure 16. Push back rack system

lanes, only the set of rails are exposed. In most systems, the last load is placed directly on the rails. The depth of the rack system is limited by the maximum weight a lift truck can push without undue strain on the drive system and/or fork lift mast.

As with the drive-in and drive-through rack systems, the lift truck driver needs to operate the push back system with great care. One example that demonstrates the need of a skilled lift truck operator presents itself during the load retrieval process, which is like removing pallets in reverse order. Because the loads are free to flow toward the front of the lane, or rack face, the lift truck driver must control the removal speed to keep subsequent loads from free-flowing to the front of the system. As with the other types of racks, the product dimensions (weight and height) and volume will determine the lane depth and the number of levels in the rack system. For some commodities, especially pallets stored at higher shelf levels, the weight and force of the commodity flowing toward the rack face at a high rate of speed and pallet loads that are not secure, could be a very dangerous situation for both facility staff and the product. The deeper the lanes are within this system, the greater the force of collision between two pallets can be at the rack face. Additionally, deep lanes can also present other challenges, such as pallets becoming blocked or jammed in a lane.

Due to the complexity and extra cost associated with this type of rack system, the push back rack is usually limited to two to five positions deep. Push back racks are best suited for medium- to fast-moving SKUs operations.

Due to the type of storage and retrieval system where loads are placed at the rack face, the push back rack system does not require special forklift attachments.

Gravity Flow Pallet Racks or Live Pallet Storage

This type of storage system is very similar to the push back rack system in its selectivity and storage density. However, unlike the push back rack system, gravity flow racks provide FEFO or first-in, first-out. The gravity flow racks consist of inclined rails (rails allow loads to move by gravity from the loading end to the unloading end); these rails have skate-like wheels mounted within them (plastic or metal, depending on manufacture), and, in turn, have carts that glide along the rails, moving the product down the lane. In these modules, pallets are stored on what is, in effect, a gravity conveyor, the pallets are loaded from the back (high end) of the rack and flow to the front (low end) by gravity. Having roller skate-like wheels mounted in the rails allows pallet loads to be inserted into one end and retrieved from the other end, which results in a FEFO retrieval system (see figure 17).

Unlike the push back rack system where the forklift driver is responsible for controlling the speed of the pallets; under the gravity flow system the speed is controlled by speed retarders or speed controllers (break wheels). Retarders are spaced out on the rail and provide consistent breaking action. Pallet loads are brought to a full stop by ramp stops. If the flow of a pallet is interrupted (bad pallet or faulty container), it would be necessary to free the load by other means, which is frequently dangerous and time consuming.

This type of racking system is best suited for temporary storage of products that expire easily, such as food or other perishable goods. Therefore, this type of system is mainly used for those items with high-pallet inventory turnover and with several pallets (same products) on hand.

Figure 17. Gravity flow rack

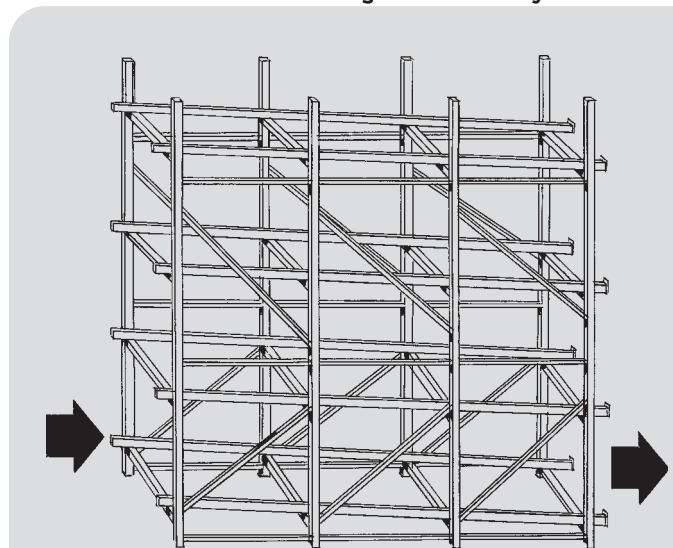

Pallet Storage Systems Selection

Each of the above mentioned pallet rack systems have advantages and disadvantages, as well as their own strengths and weaknesses; the choice is usually based on cost as it relates to the facility's products. It is generally known that any storage system choice carries significant implications—from the initial cash outlay to ongoing systems maintenance and upkeep cost. A key to selecting the appropriate pallet racking system configuration is to assign each SKU to a specific pallet storage system and match the activity and inventory profile of the SKU. The following list is a guide to the selection process:

- cost per position (anticipated rack configuration per load)
- storage density
- load access
- load dimensions
- type of lift truck required
- ease of insulation
- type of warehouse facility
- desired aisle width.

A thorough breakdown and analysis of the list above will help guide managers select the most appropriate cost-effective storage system for their facility.

Dynamic Small Product Storage/Picking Systems

Figure 18. Horizontal carousel

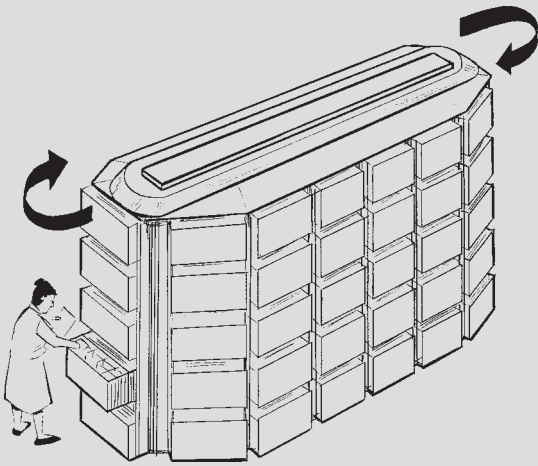

Carousels (*horizontal and vertical*)

As the name suggests, carousels are mechanical devices that store and rotate items for order picking. Carousels can be described as a series of bins that are linked together. For most carousels, the bins rotate on a continuous chain-like structure and are mounted on an elongated oval track. There are two basic types of carousels: horizontal and vertical (see figures 18 and 19, respectively).

Carousels are examples of dynamic, small-products storage systems where material is moved to a fixed location, and where picking and stocking take place. In this type of system an individual is placed at the fixed location to store or collect inventory items. The basic concept behind a carousel system is that inventory (bin with products) is brought to an individual rather than an individual going to the storage area to pick or stock products.

Many facility managers consider the carousel system a cost saver, mainly because it eliminates human travel and aisles, and the products are brought directly to the picking station. Managers must realize that the carousel is best suited for small products when there are many SKUs. One example of a well-suited product for a carousel system is pharmaceuticals and other similar products. In addition, the computer has enabled automatic storage/retrieval systems (AS/RS) to offer benefits for high-volume, small products or *broken lot picking*. Vertical carousels can range in height from 1.8288 to 10.668 meters. The length of carousels can also vary, from several meters to extending to well over 21.336 meters.

Many of today's carousel systems are linked to computer systems. The computer is considered to be far more accurate in tracking information and controlling all aspects of product management. Moreover, robotic load and unload devices that interface with carousels have been developed, which has also contributed to needing fewer person-to-machine contacts.

Horizontal carousels are usually top-driven or down-driven, and can be designed to be either intermittent or continuous-run operations. As mentioned earlier, most carousels are used to store and retrieve small product items, and can be activated through a manual control or from a computer. Horizontal carousels can vary in length and height (4.572–30.48 meters long and 1.8288–7.62 meters high). As in the requirements for large storage pallet racks, the product and building dimensions direct the carousel's configuration. Additionally, if facilities are planning to computerize their carousel system or systems, serious consideration needs to be given to the facility's information technology (IT) capacity, as well as IT capacity and support from outside organizations, and its short- and long-term costs.

Facility managers should also be aware that other dynamic storage systems are available in today's market. These systems include (1) mini-load automated storage and retrieval systems, (2) movable-aisle systems, (3) conveyor systems, and (4) automated item dispensing machines. Each storage system has its own advantages and disadvantages, and each system is best suited for certain products and operations. These storage systems will not be discussed in this document. However, you can find information about these systems, as well as all types of warehousing rack systems through the following web sites: (1) Material Handling Industry of America (MHIA) <http://www.mhia.org/>, and (2) Dexion (based in Europe) <http://www.dexion.com/>. These web sites not only offer product information but also provide links to many other organizations and warehouse equipment.

Small Static Product Storage Systems

Bin Shelving Systems

Bin shelving system designs can range from simple, open shelving to complex combinations of shelf accessories. Unlike other storage systems, static shelving systems have not changed much over the years. It remains one of the oldest and most popular storage equipment for small products. Small static shelving is usually constructed of light-gauge cold rolled steel. The design of most static configurations includes four vertical posts that support one or more horizontal shelves. However, no matter how simplistic this storage equipment appears to be, warehouse management must also conduct the same careful planning that they use in preparing for dynamic and pallet storage systems.

Figure 19. Vertical carousel



Figure 20. Two general types of shelving, open and closed

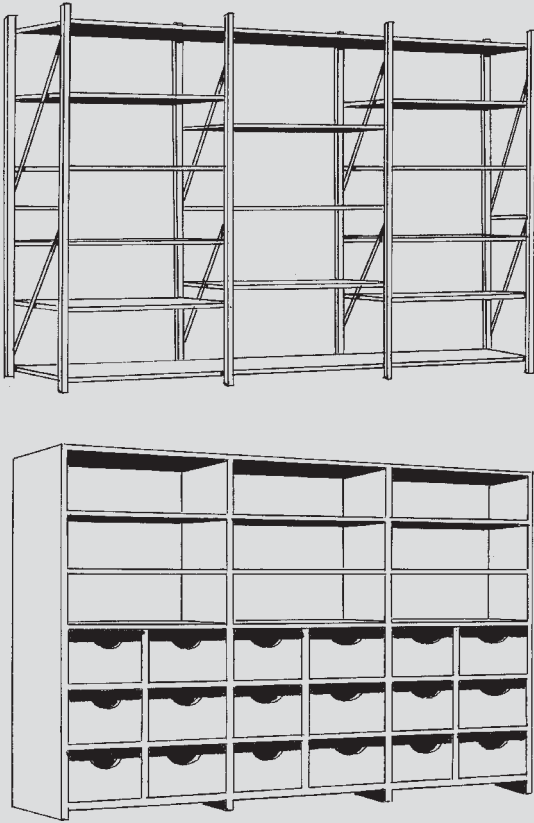

As you can see from the example in figure 20, there are only two types of static shelving; however, this shelving exists in a wide range of standard sizes. Many warehouse managers consider space to be underutilized with a static shelving system. One reason given for space inefficiency is vertical space. Often, for example, the shelving is only 2.1336 to 3.6576 meters high in a warehouse with 6.096 or more meters of ceiling clearance, resulting in underutilization of product storage space. Another common space utilization problem with this type of shelving involves underutilization of the inside dimensions of the actual shelving. One example noted is that many times the product itself does not fill the shelf or specific bin. The primary result of inefficient use of space means is that a large amount of unnecessary floor space is required to store products. The greater the floor space area, the greater area that pickers must travel, which results in more time spent walking to pick products, which then results in greater labor costs and lost time.

Modular Storage Drawer Storage

This system is called modular because each storage cabinet houses modular storage drawers that are subdivided into modular storage compartments. Drawer heights range from 0.0762 to 0.6096 meters, and some systems can hold up to 181.43695 kilograms of product (see figure 21).

The modular storage system's biggest advantage over bin shelving is the large number of small items it can store, and yet be available for the picker in a relatively small floor space area. The smaller the items, the more difficult and expensive it is to use bin shelving. Just the opposite is true for drawer storage with a small volume; small products are well suited for this type of system.

As unimportant as this may sound, it is essential to have this information before this storage system is selected. Because the drawers are pulled out in the aisle for picking, no space is needed above each SKU for the picker's hand. A bin shelving storage system, however, must have this space to accommodate the picking activity.

One major disadvantage of this drawer system is the high initial investment cost. As mentioned earlier, the smaller the product to be stored, the more economical the modular drawer is; and the larger the product, the more economical shelving becomes. Depending on the facility's products and operation, the most favorable small product

Figure 21. Modular storage: drawer cabinet with partitions

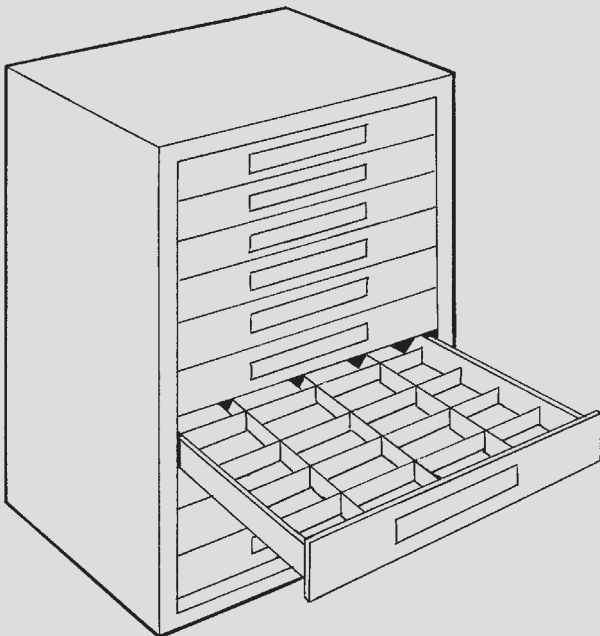

storage system includes a mixture of shelving and modular drawer storage to accommodate a full range of the facility's products, as well as running an efficient warehouse.

Gravity Flow Racks (carton flow racks)

Carton flow racks are non-pallet types of storage systems and are similar to live pallet storage systems. The gravity-type racking system uses two wheeled tracks (made of plastic, metal, and other types of durable material) in each lane to allow the load to flow from the rear of the system (storage area) to the front, where the retrieval (picking) is completed. Cartons are initially placed in the back of the rack (high end) from the replenishment aisle and rolled toward the front (low end) so they can be picked. This system is typically used for SKUs where loads are divided into individual cases and stored according to product and carton size (see figure 22).

This storage system does accommodate FEFO, and reduces the number of aisles required, unlike the pallet rack systems. However, the gravity carton system requires double the handling of cases (cartons), and is not well suited to high-volume products.

Additionally, with this system, a bay is usually organized into several shelf levels high, which are further divided into multiple lanes. The lanes can accommodate individual carton loads and, on most systems, the lane width is determined by the position of the adjustable shelf guides. As referred to earlier, an advantage of this type of system is that one carton of each line item is located on the pick face so the picker has a large number of SKUs in a small area. This situation also reduces walking time and labor requirements.

Figure 22. Gravity flow racks



Material Handling Equipment

Introduction and Background

Significant advances have been made in the material handling industry within the past five to seven years—from the most sophisticated counterbalanced lift trucks to the simplest manual low-lift trucks. Today, with the advent of improved technology and sophistication, modern material handling equipment has become more complex than in the past. Extensive research and analysis is required before the final equipment selection is made. More complex functions also means that the average user needs to understand more about their jobs and receive more comprehensive training.

Thus, in keeping with the focus of these guidelines, this section provides you with information on several types of equipment that are available today: (1) low-lift (manual and electric), (2) high-lift (electric and engine powered), and (3) narrow-aisle equipment. We will also discuss other types of material handling equipment relevant to this document.

Note that the forklift and low-lift equipment, as well as other types of material handling equipment, are only one part of a material handling system. As discussed previously, planning and how it relates to the selection of warehouse equipment—such as racking systems—and how these systems and material handling equipment need to parallel each other in all aspects of the planning stages are extremely important. This section expands on aspects of the planning process, and presents the characteristics of the material handling mechanisms of a warehouse system. A functional and well-run warehouse system should be treated as a carefully designed and properly integrated unit, combining all aspects of warehousing. Warehouse systems need to operate together so the overall performance is smooth, efficient, and, above all else, safe.

The planning process can be demanding, but it can also be rewarding. It can educate management, and provide direction and a vision to a facility's operation, which, will produce long-term benefits by ensuring that you have the right equipment for your facility.

Many aspects of warehousing have made significant advances through the years, but fundamental principles have remained the same. All lift truck equipment, for example, have one thing in common—they are designed to lift and transfer loads, of all form and sizes, that are too heavy for safe and unassisted storage and retrieval. Material handling equipment has greatly improved warehousing and distribution operations.

Because the placement and retrieval of products is the main task of material handling equipment, warehouse management must review their specific needs and select the correct equipment to meet those needs. Before the selection of any type of material handling equipment for any warehouse operation can be completed, primary criteria must be carefully studied and clearly defined.

A forklift, in its simplest form, can be described as follows—

1. It carries loads on two elongated pieces of steel called forks. Loads can be pushed, lifted, or tiered; loads can be carried on other attachments that are fastened to a mast.
2. The mast is mounted ahead of the main body of the vehicle to provide the lifting and stacking of loads.
3. It operates on a hydraulic system, which allows the mast to lift and lower loads.

4. It is also—
 - a. a movable motor vehicle
 - b. a self-load vehicle
 - c. counterbalanced
 - d. self-propelled wheeled vehicle that can carry an operator (runs on an internal combustion engine or is powered by an electric motor that runs on a power cell or battery).

Five broad categories of forklifts include the following:

1. This group consists of a three-wheeled unit powered by an electric motor; the operator is seated or in a standing position (sit-down units are counterbalanced).
2. This group is powered by an electric motor and is suited to narrow-aisle work. If needed, the equipment can be installed with extra reach/swing mast applications.
3. This group is also powered by an electric motor and the operator usually walks behind it or operates it in a standing position. Both the high-lift and automated pallet models are counterbalanced.
4. This counterbalanced class of forklift has a cab with controls; it runs on an internal combustion engine.
5. This counterbalanced class of lift truck has a cab built to sit or drive, and is powered by an internal combustion engine.

General Selection Criteria to Determine Equipment Needs

It is not a simple assignment to select a forklift or any other type of material handling equipment. With more complex equipment on the market today, the average user or warehouse management team may be overwhelmed. They may not know what equipment they need. Without proper planning and research, the questions that need to be asked and answered may not be asked before a selection is made. A good starting point in specifying material handling equipment, such as lift trucks (low-lifts and high-lifts) and manual low-lifts (also known as hand pallet trucks), is to review and examine the following criteria. You will notice that some of the criteria is the same or similar to that in the rack selection:

- What is the load (including the physical properties of the product to be handled—height, weight, overall dimensions)?
- What will the equipment accomplish in each specific area of the warehouse?
- What is the type and condition of the physical structure (building) where the equipment will be used?
- Will the equipment be used outside the facility; if so, what type of surface and landscape will you find, and what other challenges might the operator of the equipment encounter?
- What is the condition of the facility's floors; are there load limits on the floors?
- What is the overhead clearance of the facility (minimum and maximum)?
- What is the height of the doorway that the equipment will pass through?

- What is the height of the vehicle?
- Is the racking system, as well as other storage systems (bins, shelving, etc.), compatible with the material handling equipment?
- What aisle width is required?
- Where is the nearest dealer located?
- Will spare and new parts be available and at a reasonable cost?
- Will the dealer be able to provide on-site technical assistance?
- What is the cost of the equipment?

In addition to the selection criteria above, an appropriate operator training program must be incorporated into the planning process. One of the most important components in the selection process is to consider all safety features and training strategies before making a purchase. A safe speed for a fork truck is much more important than maximum speed. Lift truck operators must be trained in the proper use of equipment. If a lift truck and other material handling equipment are not used in a safe and efficient manner, workers can be seriously injured and/or miss work. Training will prevent most of these situations. Improper training will also result in the facility not receiving the maximum return on their investment; they may lose money because of product and structural damage. Most of the major lift truck manufactures offer drivers training programs (included in the purchase package), that can be tailored to specific models of lift equipment.

In determining a facility's needs, the process of selecting a forklift means that you look at specific equipment variables. For most equipment, the variables can be divided into three distinct categories:

- human (personnel)
- mechanical (equipment)
- operational (warehouse facility and functions).

Human Variables

- Degree of skill required to operate a forklift or other material handling equipment.
- Certain high-lifts and some larger equipment may require different degrees of physical skills (depth perception and physical abilities).
- Severity of fatigue caused by operating the equipment.

Mechanical Variables

- Travel distance (determine an electric truck's power plant and ability to sustain an eight-hour shift).
- Physical characteristics of the equipment (maximum lift capacity, stocking heights of certain equipment, speed, operator comfort, turning radius, etc.).
- Required maintenance schedules (determine the amount of time the equipment will be unavailable due to routine service maintenance).
- Dealer location and availability of parts (new and used).

Operational Variables

- Type of facility (size, ventilation system, building constraints, etc.).
- Traffic patterns of equipment and staff (volume of product, human congestion, and width of aisle and loading docks).
- Type of surface or floors (impact of the size of equipment, type of tires, and impact of the power plant capacity).

The lists above do not include all factors; however, they do address some key variables that impact the equipment selection process. If, after a thorough analysis, the facility is still unsure about purchasing a particular piece of material handling equipment, a financial evaluation may be the final step in the selection process. The initial cost and the maintenance cost may be the determining factor for the equipment selected.

Lift Truck Types/Classifications

In the following section, you will learn more about some of the more popular material handling equipment (often called storage and pallet retrieval systems) used in warehousing today. Additionally, concentrating on specific warehouse equipment was considered to be the most appropriate for these guidelines. You can find infinite variations and configurations that can be incorporated in the list of equipment. However, to describe each type and classification is beyond the scope of this document. The primary focus is on two classifications of lift trucks:

1. Low-lifts raise loads 0.1016 to 0.1778-plus meters above the floor; and consist of manual pallet jacks, and electronic (walkie and rider) pallet jacks. When fully lowered, the steel forks rest about 0.0508 meters from the surface.
2. High-lifts, which consist of many different design features, can raise loads to a height of 12.192 meters or more. All high-lift trucks are powered by either electric or internal combustion engines. These types of lift trucks include rider (stand or sit-down) models.

The following section will provide general and technical information, as well as illustrations for the material handling equipment. The equipment described includes—

- low-lift equipment (manual and electric)
- high-lift equipment (electric and engine powered)
- general principles of a counterbalanced forklift
- additional technical aspects
- narrow-aisle trucks
- turret trucks and hybrid storage and retrieval (S/R) vehicles.

Low-lift Trucks

Low-lift trucks can operate manually or electrically (see figure 23). The manually operated low-lifts are usually called *pallet jacks* or *hand pallet jacks*. They move parallel to the floor surface and move vertically by a manual pump effort. The manual pallet jack is principally used whenever loads, grades, and distances are small enough that a forklift or another type of power truck-type equipment is not needed. This type of low-lift is flexible and can be a real *workhorse* for a facility. It has a fully sealed, cast iron block hydraulic pump (self-contained). Its forks (approximately 0.1524 meters wide) come

equipped with integral slides that offer rigidity and easy pallet entry and exit. It is user-friendly equipment that requires little training for utilization, and can be used throughout the warehouse, loading docks, or inside trucks of all kinds. It provides exceptional maneuverability and flexibility of operation.

The electric low-lift model, also called walkie-type trucks, are considered a hybrid of pallet jacks. These trucks are moved by an *on-board* rechargeable battery (see figure 24). The batteries provide the power for the lifting and powering and transporting motions. Both the manual and electric model low-lifts operate from the floor, are self-loading, and are constructed to fit between the top and bottom boards of a double-faced pallet. The speed and load capacity varies with each model. Average speed for this type of walkie is about 5.9546 kilometer per hour (kph). Again, there are many different models and sizes. The powered walkie-type pallet jack is used in situations similar to the manual pallet jack. However, the basic difference is that the powered truck is designed to transport heavier loads over greater distances and at faster speeds. The electric low-lift equipment provides great maneuverability and is able to turn inside trucks. Walkie-types are designed so the operator can see the fork tips for pallet entry; its battery swings out for easy quick maintenance checks.

Within the low-lift powered category, there are two basic types: rider and riderless. When operating a riderless or walkie-type, the operator steers from a walking position in front of the low-lift. The rider pallet jack has a built-in compartment for an individual to either stand or sit in this vehicle (see figure 25).

Selecting low-lift walkie trucks (rider or riderless) requires a careful review of the suitability of a particular type of walkie for a specific function within a facility. In addition, aisle and height requirements must also be well matched with the vehicle choice. Again, in this category, there are many options and configurations. The selection must match a facility's functional requirements.

The usual required dimensions of right-angle turn for low-lift walkie trucks range from 1.524–2.1336 meters, and the required dimensions of an intersecting aisle is approximately 1.524–2.1336 meters. Again, these required dimensions will vary depending on the type of walkie selected, and it is essential to review all required dimensions with the manufacturing representative or engineer during the planning and selection process.

High-lift Trucks

As with the electric low-lift material handling trucks, high-lift trucks come in many different variations and configurations. However, this type of equipment is larger and has a much

Figure 23. Manual low-lift hand truck

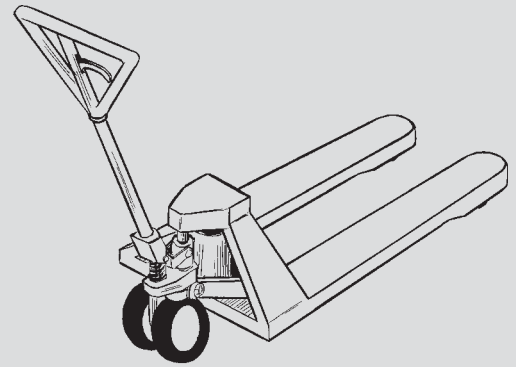

Figure 24. Electric low-lift truck

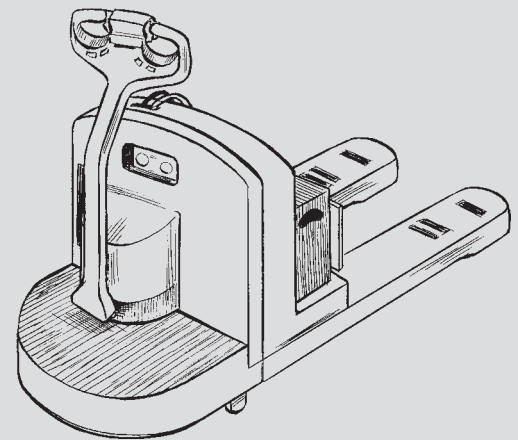
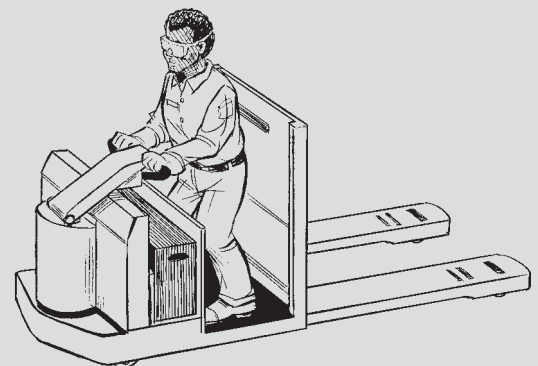
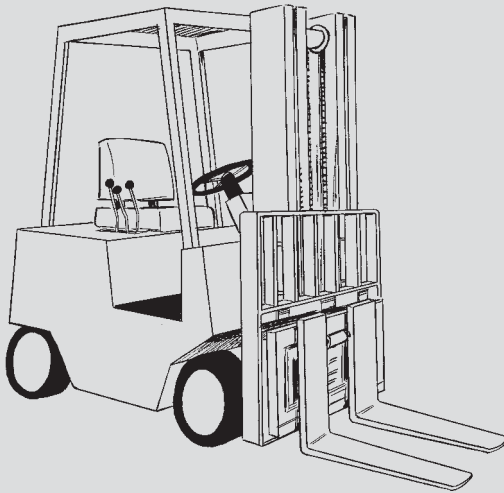

Figure 25. Low-lift electric rider



wider lifting capacity range. The high-lift equipment can lift 453.5924 kilograms to more than 6803.886 kilograms. No matter what the lifting capacity may be on a piece of equipment, raising loads high into the air requires certain design modifications to the equipment. Thus, over the years, manufactures have engineered and developed various types of high-lift equipment, including counterbalance high-lifts, narrow-aisle, side-loader, turret, and high-lift S/R machines to better assist the warehouse process. For the following discussion, the focus will be on more generic equipment and how information about this equipment can be useful to the readers of this manual.

Figure 26. Counterbalance lift truck—rider



Counterbalance Lift Trucks

As the name implies, a counterbalance lift truck uses a counterbalance near the back of the truck to stabilize loads that are being transported or lifted to a storage area and retrieved. Counterbalanced lift trucks can be powered by either an internal combustion engine (gas, diesel, or liquefied petroleum gas [LP Gas]), or by battery. With a capacity of 1360.7772-plus to 2721.5544-plus kilograms, counterbalance trucks work well for dock, cross-dock, and dock-to-stock applications. Counterbalance lift trucks offer a wide range of masts and attachments to handle all types of loads. Today, most lift trucks accommodate ergonomic driver control and have relatively easy maintenance access. Additionally, some provide a full driver cab. The counterbalance lift truck is a very flexible piece of equipment; it is considered to be the *backbone* of the warehouse industry. Counterbalance trucks come in two basic designs: the sit-down rider (see figure 26) and the stand-up rider (see figure 27).

Figure 27. Counterbalance lift truck—stand-up (electric)

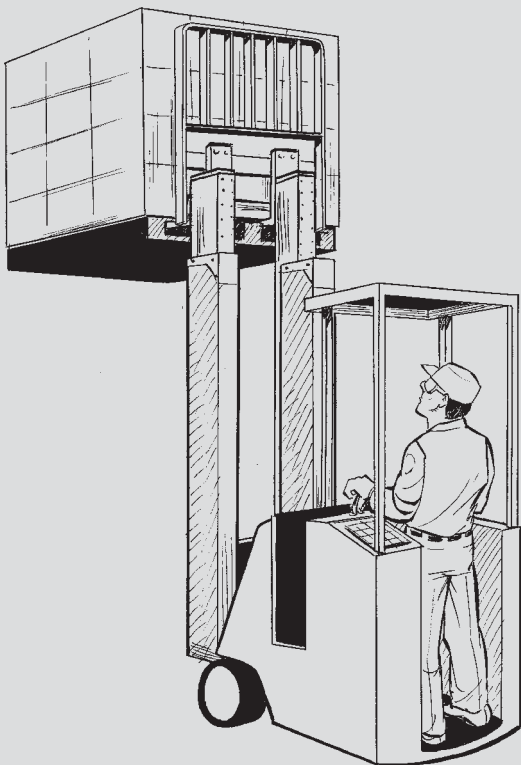

Anatomy of a Counterbalance Forklift

Several features are common to all types of forklifts, such as tilting and rotating wheels to aid maneuverability, safety tails mounted on the sides of the mast, reversing lights, and many other similar features. However, before you can understand the basic principles of counterbalance equipment and plan for the purchase of this equipment, you must first know the basic structure of the equipment and the names of the fundamental lift parts or the *anatomy* of a counterbalance forklift (see figure 28).

The eight most basic parts of a counterbalance forklift are—

1. **Overhead guard:** This protects the operator from objects that may come loose from a load. As part of safety regulations, it is required in most international locations. An overhead guard also prevents the operator from being ejected and crushed if the lift truck turns over. Due to the lift capacity, low-lift equipment may be exempt from having the overhead guard.

2. *Mast:* The mast operates hydraulically and is a vertical assembly. The outer mast frame or track is stationary with highly lubricated inner guides or roller bearings that raise and lower the mast. Additionally, masts are available in multiple stages (1, 2, 3, and 4 levels). The technical name for the 2-stage is duplex mast, a 3-stage is called a triplex mast, and so on. Most masts operate through chain configurations. Today's equipment may have a 3-stage mast but have a low overall forklift height, allowing the lift to complete difficult tasks and, at the same time, negotiate through low passageways (dock doors and supply vehicles).

Figure 28. Parts of a counterbalance forklift

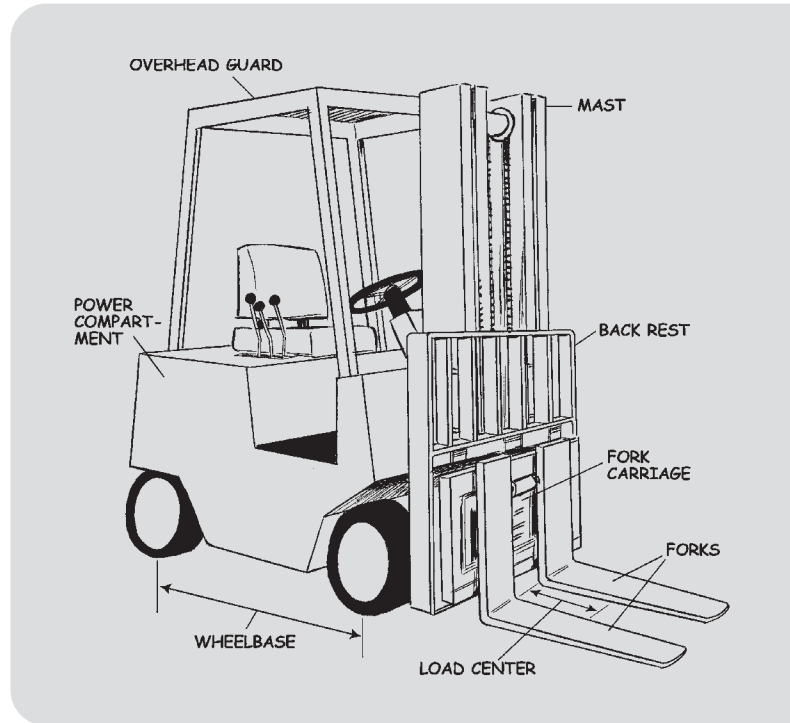

3. *Fork carriage/Back rest:* This part of the lift is used mainly for mounting the forks and other attachments. It is also a lifting base for loads, and enables the operator to adjust the forks to different widths for different size loads. In addition, the carriage uses the back rest to prevent loads from coming apart when the mast is tilted back, and to help guide loads when it is in motion. Any modification of the fork carriage or forks (for extensions) must meet strict safety specifications before operation.
4. *Forks:* The forks, usually made of steel, vary in length and thickness. There are many different size forks, which can be interchanged for different jobs. It is important to note that if different size forks are going to be used, the operator and warehouse staff need to be aware of added safety measures that may be required for a particular assignment. Operators should be aware of the capacity of the forklift and the capacity of the forks. For example, don't overload the forks as this may bend and weaken the forks.
5. *Wheelbase:* As illustrated later in this document, the wheelbase is simply the distance between the front and rear wheel. The wheelbase determines the load capacity, turning radius, aisle space needed for right-angle load stacking, and maximum grade (the distance between the bottom of the forklift and ground) for a typical lift truck.
6. *Load center:* The load center is located in the front of the forklift—from the front face of the fork to the center of gravity of the load. The distance of the load center base was designed for and is determined by the forklift capacity.
7. *Tires:* Several different types of tires are used (solid, cushion, and pneumatic), and each can have a different structural design for a specific purpose.
8. *Power source:* This supports the power plant of a forklift, such as electric batteries or internal combustion engine. The forklift load capacity will determine the size of a battery or engine required for maximum capacity of the vehicle.

It is recommend that warehouse management articulate their needs to a manufacturing representative, then discuss and review their needs in detail. The warehouse must then match these needs to the appropriate equipment.

General Principles of a Counterbalance Forklift

When a counterbalanced forklift picks up a load, the fulcrum or pivot point for the counterbalancing action, moves toward the centerline of the front wheel (see figure 29). If the safe weight of a forklift exceeds its capacity, the center of gravity moves forward beyond the fulcrum (pivot point) and the forklift tips, falling forward. In its simplest form, the principle behind the counterbalance forklift occurs when lifting a weight; the forklift must be less than the weight attached to the rear of the forklift. The weight of the load being picked up must be safely counterbalanced. In most vehicles, the counterweight is made of lead material. In addition, the total counterweight may also consist of the engine or battery and frame (see figure 29). When a forklift is used for a different job and may require special lift attachments (carton clamps, barrel clamps, revolving carriage, boom, side loader, bale clamp, etc.), the rated capacity of the forklift should be increased. However, as mentioned earlier, safety specifications need to be researched thoroughly before operation.

Manufacturers must adhere to a specific safety criterion in the production of a counterbalance forklift. Most countries have a body that establishes and oversees the safety standards. In the United States, for example, the Occupational Safety and Health Administration (OSHA) has established the safety regulations for manufactures and, by law, these regulations must be met.

Additional Counterbalance Technical Information

As the selective pallet rack is considered the benchmark of pallet storage, the counterbalanced truck is considered the benchmark for storage and retrieval vehicles. The counterbalanced lift truck is the basic and versatile material product mover. Again, there are numerous variations and configurations for high-lift equipment. Following a through analysis, facilities will have different needs that require certain equipment to fulfill those needs. Industry people have stated that the counterbalance forklift is by far the most flexible piece of equipment in the area of storage and retrieval. The counterbalance forklift can store products within an aisle and load and unload products in a trailer, travel on ramps, and handle several types of unit loads in and out of storage modules. The counterbalance forklift can store products within an aisle, and load and unload products in a trailer. This vehicle

is relatively easy to learn to operate and versatile to use in many of the day-to-day warehouse functions. However, some users of this vehicle consider the required turning radius a major drawback.

The maneuvering space needed to operate lift trucks effectively is critical in the planning and designing of warehouse operations. All trucks have two turning radii: outside and inside. The outside radius is measured by the overall swing of the truck frame to the furthest point of the rear frame. The inside radius or the pivot point is usually 0.0762 to 0.1016 meters outside the truck drive wheels (front wheels). Thus, this equipment cannot pivot within its own *footprints*.

The most common counterbalanced lift truck, for example, with a capacity of 1360.7772 kilograms, requires approximately 3.6576 meters between storage aisles for a right-angle storage turn (considering a 1.2192-meter × 1.016-meter pallet) to stack merchandise in rows facing the aisle (see figure 30). In another example, a typical 1814.3695 kilogram capacity counterbalanced electric rider (with load dimensions 1.2192-meter × 1.016-meter

Figure 29. General principles of counterbalance lift truck

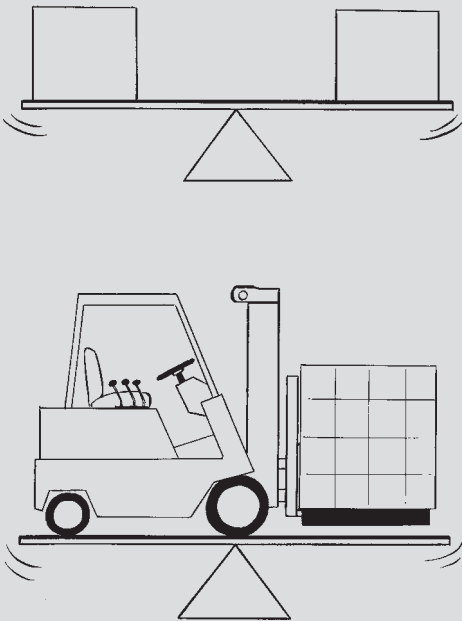

pallet) has a right angle of 2.1082 meters, plus the load length, which is 3.3274 meters (2.1082 + 1.2192 = 3.3274). In addition, you must add 0.1016 meters (0.1016 meters to allow for adjacent loads) for clearance, for a total of 3.429 meters. In the last example, we assume a 90° turn within the aisle, with a load.

Another example of how to calculate turning radii for a full right-turn angle (in metric) with a pallet using 0.1524 meters for operating clearance is as follows:

Formula example:

1. Use manufacture listed right-turn angle (forklift) + length of pallet + operating clearance (0.1524 meters) = full right turning radius in meters.

2. **Example:**

Lift truck right-angle turn	-	1.9304	m
Length of pallet	-	+ 1.2192	m
Operating clearance	-	+ 0.1524	m
Total	-	3.302	m

Figure 30. Right-angle turning radii

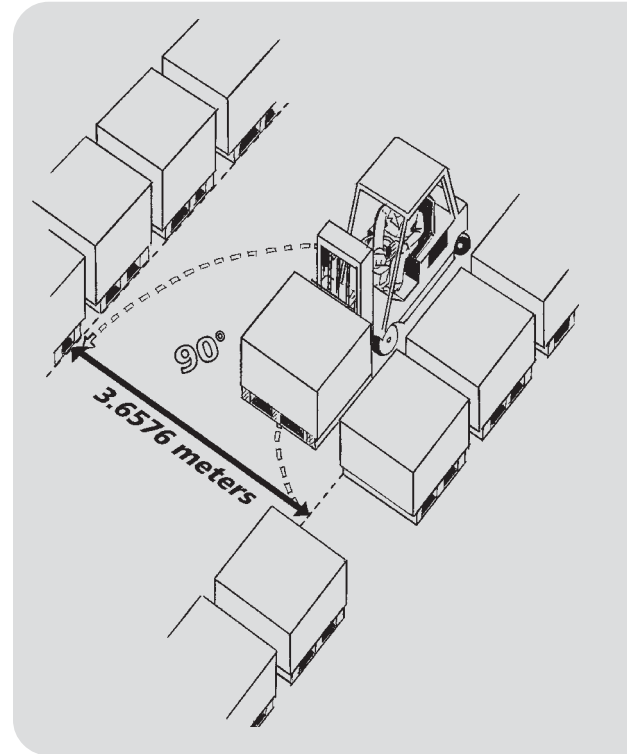

You can obtain more detailed information relating to turning radii from the equipment manufacturer. In general, managers need to plan for right-angle stacking and cross-aisle maneuvering calculations based on truck turning radii, truck frame configuration, and unit load length and width.

The following recaps the key factors to consider when selecting counterbalance equipment:

- load capacity and dimension
- lift height
- travel and lift speed
- maneuverability
- ramp capability.

Together, the facility management and manufacturer must evaluate the relevance of each of these factors to determine whether a specific design will meet the needs of the facility and perform effectively and efficiently.

Narrow-aisle Trucks

Lift truck manufactures have produced variations on lifts that can operate effectively in narrower aisles. Narrow-aisle equipment is best suited for small areas; it was developed to maximize space with manual systems. The narrow-aisle designs are better known as straddle trucks. There are two basic types of narrow-aisle trucks: the standard straddle truck and the reach straddle truck (single and double reach). Within this group there are rider designs and stand-up designs. Narrow-aisle trucks are always battery operated, and many accept attachments to meet all types of special handling requirements. When operating narrow-aisle equipment, the load is carried between the front outrigger wheels to minimize the need for counterbalancing.

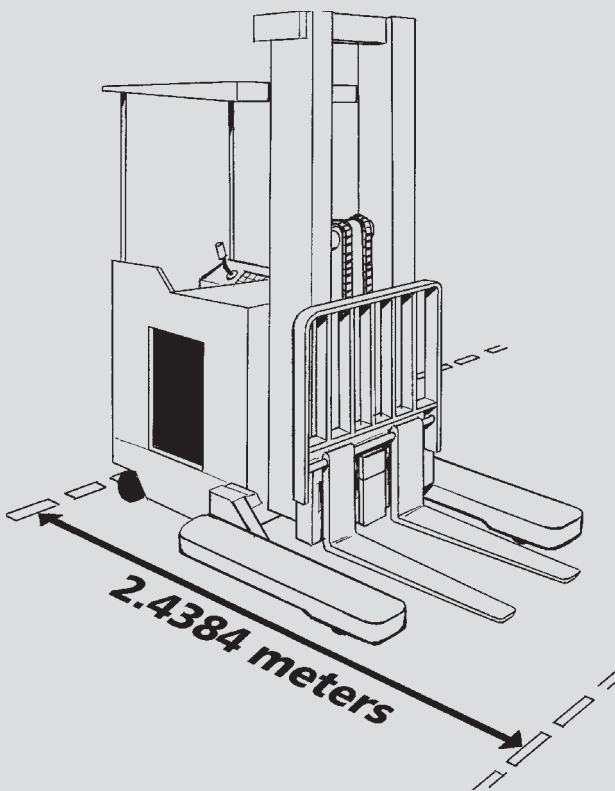
Figure 31. Standard straddle truck**Standard Straddle Truck**

Unlike the counterbalance truck, the straddle truck was designed to work within narrower stacking aisles. The efficiency and economy of a straddle forklift has been demonstrated in actual field use for many years, under many different conditions. The straddle forklift has the ability to pick up, stack, and unstack loads. For loading and unloading, its open-ended front allows the entire mast section to be extended so that the forks are positioned just beyond the front wheels.

A straddle truck does what the name implies; it straddles the pallet (or load) with its straddle arms, also called outriggers. Thus, the spread of the outriggers must be wider than the pallet. A straddle truck provides load and vehicle stability using outriggers to straddle the pallet load rather than a counterbalanced weight (see figure 31). All straddles are fixed and are not adjustable. The capacity for straddle trucks can range from 907.1847 to 2721.5542-plus kilograms. For maximum productivity within a rack structure, you must allow enough operating clearance for equipment to work smoothly and effectively within the aisle. The single reach narrow-aisle truck can operate in an 2.4384-meter aisle (see figure 31) or approximately 1.2192 meters less than the aisle space required for the counterbalance type.

Reach Type Straddle Truck

The reach truck is a variation of straddle truck. It is more maneuverable than the standard forklift trucks and can usually operate in smaller spaces. For operations that require more versatility because of different load sizes and challenges within the facility, the reach straddle truck may better suit the facility's needs. Both the single and double reach trucks have a scissors-reach mechanism that moves the fork carriage forward into the load (see figure 32).

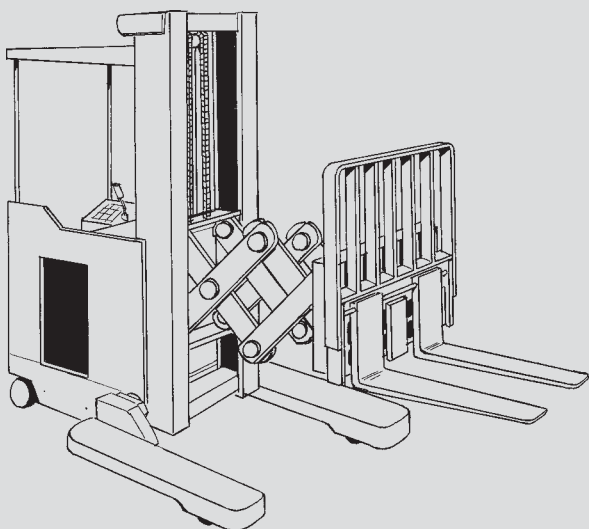
Figure 32. Double reach straddle truck**General Considerations for All Straddle Trucks**

Because the front wheels of the outrigger are much smaller than other types of counterbalance equipment, they are not designed for crossing dock plates or for jobs that require traveling over rough terrain (uneven cement floors, outside work with small stones on the surface, etc.). The surface for straddle trucks must be fairly smooth and free of debris and holes for this type of equipment to function in a safe and productive manner. Addressing these limitations, the facility may require other types of equipment for a specific job:

- for loading and unloading trucks
- for outside jobs
- for storage and retrieval operations.

Using a similar turning radii example as the counterbalance example earlier, for either the standard straddle truck or reach straddle truck, a right-angle turn would be calculated as follows: (using the same load data, 1814.3695 kilograms and a 1.2192×1.016 pallet), with a stand up narrow-aisle truck, the right angle stack dimension is 2.2098 meters. If you add 0.1524 meters for operating clearance, the total is 2.3622 meters. This assumes a 90° turn within the aisle with a load. If your pallet or pallets overhang on the rack beam, it is important to measure from pallet to pallet and not rack to rack to calculate your clearance.

Turret Trucks and Hybrid Storage and Retrieval Vehicles

These types of lifts are highly sophisticated and very expensive; they would rarely be used in warehouse operations that will use this manual. However, it is important that you are familiar with this equipment. These two types of equipment are for certain products and a more specialized warehousing operation. Typically, this type of equipment is primarily used for high-volume/high-density products.

Turret Trucks

The turret truck is also known as a very narrow aisle (VNA) truck and is designed to work in very narrow aisles. Turret trucks do not require the truck to turn when storing and retrieving loads. The lifting forks swing on the rotating mast. The load is then lifted and rotated back into the front of the truck (see figure 33).

Turret trucks usually require a guidance system (track-like system) for safe operation. This equipment requires very little aisle space (1.524 or 1.8288 meters wide), and can access load positions up to 15.24 meters or more, which results in increased storage density. It requires very flat floors to operate.

Hybrid Storage and Retrieval Vehicles

The turret and hybrid S/R systems are similar in their functions except that the hybrid operator's cab is lifted with the load. Although somewhat awkward and slow, the S/R system can operate outside the storage aisle. Hybrid vehicles require about 1.524 to 2.1336 meters within an aisle, and can store loads up to 18.288 meters high (see figure 34).

Rolling Warehouse Ladders

Facilities are able to implement an effective rack or bin system, or both, but due to the size of the facility or the expense of certain material handling equipment, some warehouse facilities are not able to accommodate any type of lift equipment for storage and retrieval activities. In these situations, warehouse

Figure 33. Stand up turret truck

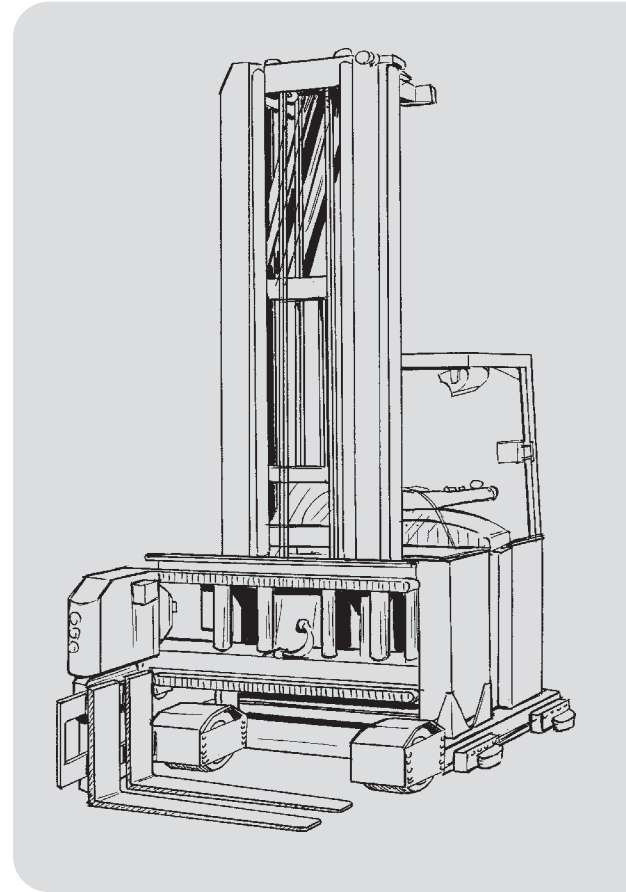

Figure 34. Hybrid turret truck

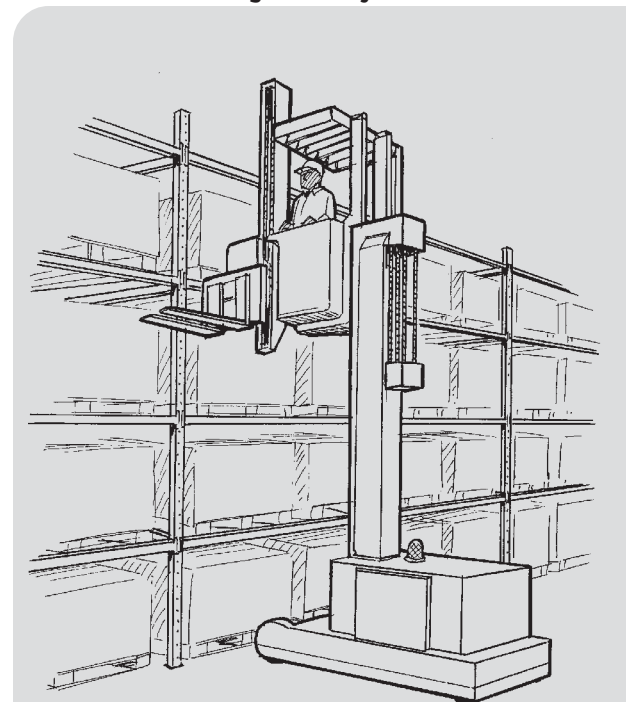
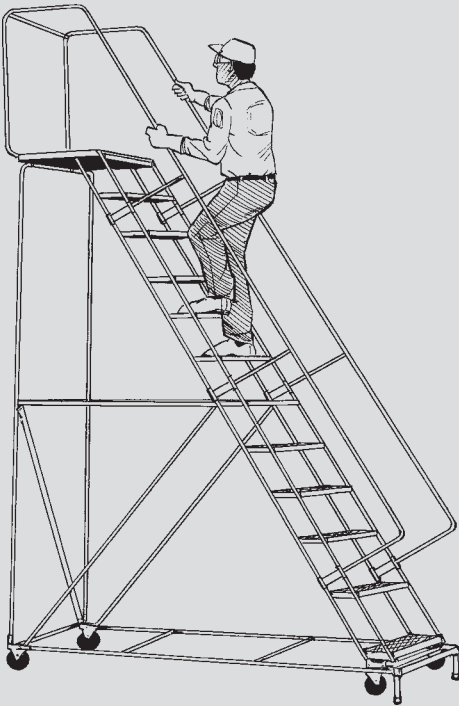

Figure 35. Warehouse rolling ladder

rolling ladders (see figure 35) may provide the service needed for actual storage and retrieval of small items. The rolling ladders may also assist in other essential warehouse requirements; managers may see the need to keep rolling ladders in the warehouse to supplement their day-to-day necessities.

Rolling warehouse ladders provide a stable, transportable platform for maintenance, stock, and order picking, and many other warehouse and non-warehouse functions. This equipment provides features such as adjustable floor levelers and anti-skid steps. Rolling warehouse ladder sizes can range from 2 steps to 15 steps, 0.508 meters to 4.8006 meters in overall height. Additional key features include—

- *Slip-resistant perforated tread:* This surface provides maximum slip resistance and comfort when sitting or kneeling on steps.
- *First-step actuated locking system:* This feature locks the ladder in place when an individual steps on the first step. The step-lock feature is standard on most models.
- *Heavy 1 1/16" diameter tubular construction:* In harsh environments, the tubular construction provides superior strength, as well as long-lasting durability.
- *Durable powder coated paint finish:* This type of finish is baked on in colors such as industrial gray or safety yellow. It provides a premium quality scratch-resistant finish that is both durable and long-lasting.

In addition, warehouse ladders are available in steel or aluminum and come in various degrees (48° – 56°) of stairway slope for easy forward ascent or descent, commonly known as *stairway slope warehouse ladders*. One of the convenient aspects of these ladders is that the workers using the ladder get the feel of a stairway, so they are more comfortable and feel safer climbing up and down the ladder steps.

For additional information relating to the equipment above, you can access the following web sites: <http://www.yale.com/> (Yale Materials Handling Cooperation, with locations in several countries), and <http://www.mit-lift.com/> (Mitsubishi Fork Lift Trucks).

Warehouse Checklist

A successful warehouse makes the most of available resources and, at the same time, complies with customer requirements. However, to meet these requirements, and to carry out day-to-day warehouse operations often leaves little time for managers and associate staff to sit down and develop both short-and long-term warehouse plans. To alleviate some of the planning time, as well as to guide managers in planning warehouse set-up activities, the following checklist can serve as a quick reference. This list is not an exhaustive list in planning warehouse operations; however, it will provide you and other managers with key issues to consider when you develop a comprehensive warehouse plan.

Key Warehouse Planning Issues to Consider for Warehouse Planning (new and existing warehouse buildings):

Building

1. *Height of building and product.* Allow space between the top of the load (product and pallet) and the lowest obstruction. This includes space for ventilation, sprinklers, and forklift load backrest (when the forklift mast is fully extended, especially if the load is shorter than the load backrest).
2. *Obstructions to the building.* Consider the slope of the roof and the placement of roof support columns and their impact on the rack configuration and other warehouse operations.
3. *Type of floor.* Will the floor material support the rack system (point load with system loaded), product, and material handling equipment? Has the material below the surface been inspected for caverns, unstable soils, etc? Does the current floor material meet any applicable seismic considerations?
4. *Temperature variation.* The temperature difference (outside versus inside) will help determine the type of ventilation needed. Additionally, high moisture content may cause the racks to rust, and may cause long-term damage to other equipment. Racks and other material handling equipment can be ordered with galvanizing to reduce rusting and corrosion.
5. *Building entering and exit locations.* What type of dock doors are in place (dimensions), or how many will be needed and how are they configured? What are the dimensions of other doorways that equipment and loads will pass through? Will you need to add doors or adjust the current doors?
6. Define the space required for packing, palletizing, repack operations, return operations, quarantine areas, high-value secure areas, maintenance areas, etc.

Load Sizes and Equipment

1. *Determine load sizes.* Calculate load dimensions for each product line (height, length, and weight).
 - Load dimensions will give you information to help determine the facility's rack configuration.
2. *Determine the type of lift truck equipment that will be used for rack storage in the warehouse.*
 - Overall top load level of the storage rack must be compatible with the maximum lift height (less approximately 0.2032 meters of *lift off* to accommodate a typical pallet height of 0.1524 meters, and 0.0508 meters of lift to get the pallet off the load beam level) of the lift equipment.
3. *Storage rack dimensions:* The basis for warehouse layout.

Warehouse Staff

1. *Determine the skill level required of warehouse personnel.*
 - What staff training will be needed (warehouse equipment, computer, management, etc.)?

2. *Determine if language translation will be needed?*

- Will warehouse materials need to be translated into local language?

Again, the above list serves as a guide for warehouse planning. Each facility will have different needs and products; however, most points on the checklist are fundamental to any warehouse planning operations.

Warehouse Management Systems

Overview

Warehouse management systems (WMS) are technologies that integrate software, bar coding equipment, and radio frequency communications to provide computerized process management and inventory control within the four walls of a storage and distribution facility.

This chapter explains the benefits of using a WMS in a storage facility, describes the technology components of a WMS, and examines the process for implementing a WMS. The last section reviews several WMS and Enterprise Resource Planning (ERP) solutions that have been implemented in countries in Africa and Southeast Asia.

What Storage and Distribution Tasks Does a WMS Support?

A WMS supports all the tasks routinely performed within a warehouse: receiving, storing, packing and shipping products, and managing inventory. The tasks commonly supported by a WMS include—

- *Receiving*: Receipt of products into the warehouse, quality assurance for some products, and staging of products for putaway.
- *Putaway*: Placing products into storage locations after they have been received by the warehouse.
- *Replenishment*: Moving products from secondary storage to primary storage locations to facilitate picking.
- *Picking/packing*: Gathering the products listed in a customer order and packaging them for shipment.
- *Shipping*: Loading packages onto transport for distribution to customers.
- *Management reporting*: Compiling and presenting data on inventory levels and locations, customer orders, and purchase orders.
- *Cycle counting*: Performing physical inventories on a rotating basis, usually according to the value and volume of each product.
- *Inventory control*: Setting the maximum and minimum inventory levels for each product based on past customer orders.

Benefits of a WMS

There are five major benefits to implementing a WMS:

1. zero information errors
2. reduced information lead times
3. increased storage capacity
4. optimal space utilization
5. increased labor productivity.

Zero Information Errors

A WMS can eliminate information errors and improve your inventory accuracy. A WMS improves inventory accuracy by verifying the identity of every product as it is received, put away, stored, picked, and shipped to customers. The system can further reduce inventory discrepancies through cycle counting: fast-moving or high-value products are counted frequently to ensure that physical counts match the recorded quantities in inventory. Any inventory discrepancies are corrected at the first opportunity.

Reduced Information Lead Times

By eliminating information errors, a WMS reduces the time and effort needed to gather and compile data on inventory and customer orders; forecast demand; plan procurements; and reports to officials, donors, and other stakeholders. With the push of a button, warehouse managers can view current quantities of all products in inventory, consumption rates per product and per customer, and forecasted demand based on the current consumption of each product.

Increased Storage Capacity

A WMS can increase warehouse capacity by enabling products to flow more quickly through the warehouse. With accurate inventory information and no information lead times, warehouse managers can reduce lead times and buffer stock. This enables warehouse personnel to provide better customer service and to store a larger variety of products in the same storage space.

Optimal Space Utilization

Many WMSs can inform warehouse personnel about where to put away products in particular locations, based on the known dimensions of both the product and the available storage space. Optimal use of existing storage space for large numbers of products will become increasingly important as organizations integrate their previously separate warehousing and distribution operations.

Increased Labor Productivity

A WMS can increase labor productivity by directing the tasks of warehouse personnel. It can also enable warehouse managers to plan for peaks and valleys in warehouse labor, based on expected tasks for a given time period.

Warehouses in developed economies often choose to implement a WMS to maximize labor productivity. In contrast, warehouses in the public sector, in resource-constrained environments, may not view labor productivity as a sound reason for implementing a WMS. The low cost of labor in such environments may make labor productivity less of a concern.

Components of a WMS

A WMS can have three components:

- software
- radio frequency communications equipment
- bar coding technology.

The software component of a WMS is essential. The other two components—radio frequency communications equipment and bar coding equipment—are optional. Many

packaged WMSs can be implemented without radio frequency and bar coding, although these additional technologies can eliminate information lead times and make inventory data almost 100 percent accurate.

Software

The WMS software is the brain of the system: it stores data on products and customers; and directs warehouse personnel to receive, store, and ship products to customers based on current inventory levels.

WMS Data

To support warehouse operations, WMSs need to collect and store data on all products managed by the warehouse and the locations within the warehouse—for example, aisles, shelves, and bins—where products are kept. In addition, WMSs collect data on customer orders and purchase orders, which allow the software to track the flow of products into and out of the warehouse.

Table 8 lists the essential data groups and data items in a WMS.

Table 8: Warehouse Management System Data

Data Group	Data Items
Product	<ul style="list-style-type: none"> ■ Product code ■ Product description
Location	<ul style="list-style-type: none"> ■ Location code ■ Location name ■ Quarantine
Inventory	<ul style="list-style-type: none"> ■ Product code ■ Location code ■ Quantity in stock ■ Expiration date
Unit of measure	<ul style="list-style-type: none"> ■ Unit name ■ Quantity of single units contained
Customer	<ul style="list-style-type: none"> ■ Customer code ■ Customer name ■ Contact information
Vendor	<ul style="list-style-type: none"> ■ Vendor code ■ Vendor name ■ Contact information
Customer order	<ul style="list-style-type: none"> ■ Customer code ■ Order date ■ Product code ■ Product quantity ordered
Purchase order	<ul style="list-style-type: none"> ■ Vendor code ■ Order date ■ Product code ■ Product quantity ordered

WMS Functions

The essential tasks of a WMS are to determine—

- How much of each product is in stock?
- Where is the stock located within the warehouse?
- When will the stock expire?
- How much of each product have customers ordered?
- How much of each product have been/will be ordered from suppliers.

Many packaged WMSs include a variety of functions designed to support more advanced warehouse operations, as well as performance monitoring; but all WMSs should have the essential functions listed in table 9.

Table 9: WMS Software Functions

Function	Description
Manage products	Add, edit, and inactivate products.
Manage storage locations	Add, edit, and inactivate storage locations.
Manage customers	Add, edit, and inactivate customers.
Manage suppliers	Add, edit, and inactivate suppliers.
Receive products	For each product received, record the quantity, expiration date, and storage location.
Record customer orders	Record the customer name and reporting period (if applicable). For each product in the order, users record the product name and quantity ordered.
Pick customer orders	For each product in the order, identify the storage location based on first-to-expire, first-out. In addition, record the quantity picked, expiration date, and storage location.
Record purchase orders	Record the supplier name and purchase order date. For each product in the purchase order, record the product name and quantity ordered.
Calculate current stock on hand	For each product, calculate quantities of stock currently in inventory based on aggregate quantities received and issued. In addition, report the location and expiration date(s) of each product in stock.
Record physical inventory results	For each product, record the current quantity on hand based on a physical inventory.
Adjust quantities of stock	For each product, record quantity added to or subtracted from stock due to transfer in, expiry, damage, theft, or other.

WMS Reports

The list of available reports in packaged WMSs is usually long. Some reports—such as picking lists and packing slips—are an essential part of routine warehouse operations. Other reports enable warehouse managers to monitor performance and identify potential inventory problems before they occur. Table 10 lists essential WMS reports.

Table 10: Warehouse Management System Reports

Report	Description
Picking list	Lists storage locations for each product in a customer order. Storage locations are listed according to first-to-expire, first-out. Warehouse personnel may use this report to assemble a customer order for shipping.
Inventory by storage location	Lists product quantities and expiration dates at each storage location. Warehouse personnel use this report to verify reported inventory quantities against physical counts.
Inventory by expiration date	Lists products at each storage location according to expiration date. This report identifies products that will expire within a specified time frame, and enables warehouse personnel to reallocate or remove products about to expire.
Closed customer orders	Lists product quantities shipped for each customer order that have been completely shipped.
Open customer orders	Lists product quantities ordered for each customer order that have been submitted to the warehouse but not completely shipped (includes customer orders that have been partially shipped).
Closed purchase orders	Lists product quantities ordered for each purchase order that have been completely received.
Open purchase orders	Lists product quantities ordered for each purchase order that have been submitted to the vendor but not completely received (includes purchase orders that have been partially received).

Radio Frequency Communications Equipment

With radio frequency communication, routine warehouse transactions can be transmitted electronically to WMS software in real-time. As soon as warehouse personnel receive, put away, and pick and ship products, the transaction is recorded in a portable device (such as a bar code scanner), and instantly transmitted to the WMS software by radio frequencies.

Radio frequency communications are not essential to a WMS, but they can eliminate time lags in data collection that can occur when transactions recorded on paper must be manually entered into the WMS software at a later time. Elimination of this data backlog enables warehouse personnel to identify inventory discrepancies as soon as they arise and to take immediate steps to correct them.

A radio frequency communications network comprises the following equipment (see figure 36):

- *Master radio transmitter and receiver (base station).*
- *Radio transceivers or antennas.* These devices are installed at various locations within the warehouse to enable reliable transmission of data by means of radio frequency from any point in the warehouse. The transceivers or antennas amplify any radio waves they receive and transmit them to the base station.
- *Repeaters.* These are optional devices that may be used to extend the area covered by radio frequency. They can be carried by warehouse personnel or mounted on vehicles.
- *Scanners.* Portable bar code scanners or fixed scanners fall into this category. These devices read data from barcode labels applied to products, storage locations, or other objects within the warehouse. After the data are read into the scanner, they are transmitted to the WMS by radio frequency. The following section on bar coding technology describes bar code scanners in more detail.

Prior to establishing a radio frequency network in a warehouse, you must conduct a *site survey*. The site survey determines the optimal number and placement of radio antennas within a warehouse. This facilitates radio communication and helps prevent *dead zones* that prevent radio transmission from certain locations in the warehouse.

Figure 36. WMS network

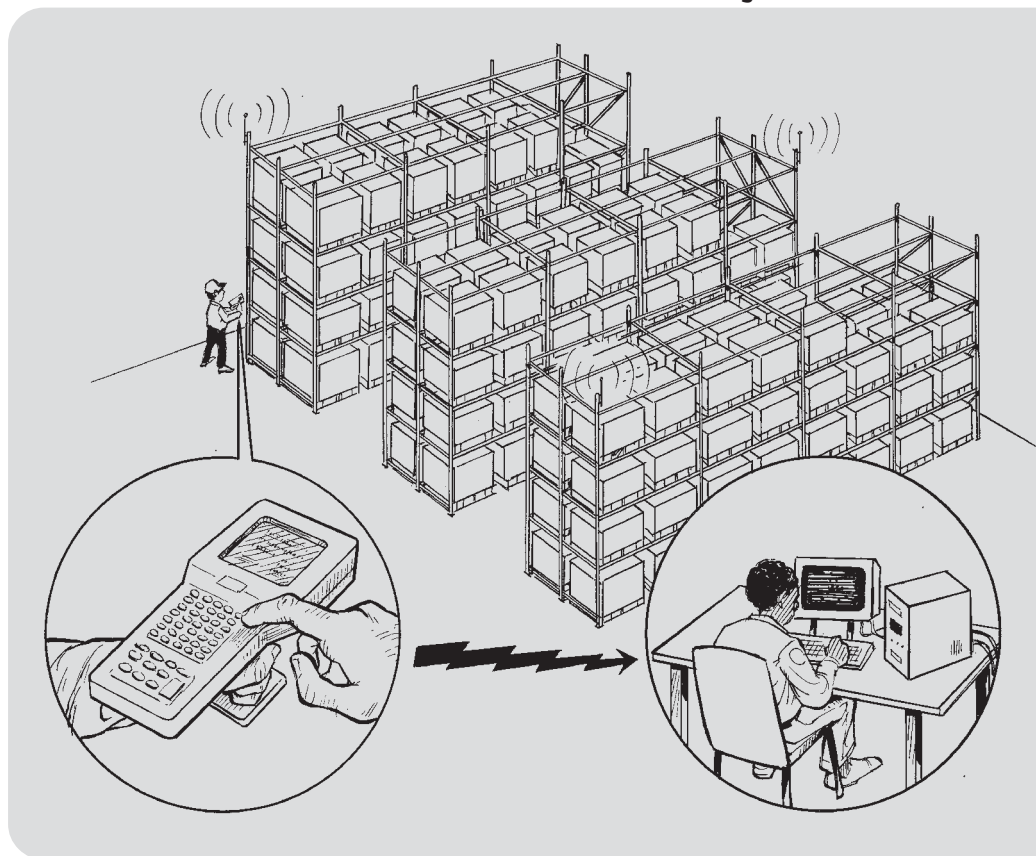

Bar Coding Technology

Background and Terminology

Many people think that a bar coding system is a device (either handheld or stationary), that when activated, automatically reads the price (and other information) from a label on an item, and then relays that information to the user (on either a screen or paper). However, this is usually not true. The data in a bar code is often a reference number that a computer uses to look up associated computer records that contain the descriptive data and other pertinent information about the item. Bar code reading is just a data input method, although it is very accurate and efficient. The most important thing to remember about bar coding is that the software that manages the bar-coded data controls 95 percent of the success or failure of an application.

What Is a Bar Code?

A bar code is a series of varying width vertical lines (called bars) and spaces. Different combinations of the bars and spaces represent different characters in a numeric or alphanumeric code. When a bar code is scanned by a scanning device, the light source from the scanner is absorbed by the dark bars and is not reflected, but it is reflected by the light spaces. A detector in the scanning device receives the reflected light and converts the light into an electronic signal. This signal can be decoded by the bar code reader's decoder into the characters that the bar code represents.

Bar codes can be created for just about any characteristic of a given product, usually called a stock keeping unit (SKU). Some examples applicable to logistics management include—

- SKU or part number
- quantity
- supplier identification (ID)
- serial number
- expiry date
- manufacturing date.

What Components Are Used in Bar Code Technology?

Bar code technology includes the following components:

- *symbologies* (or languages) that encode data to be read optically
- *printers* that produce machine-readable symbols
- *scanners and decoders* that capture the visual images of the symbols and convert them to digital data
- *verifiers* that validate the symbol quality.

Symbologies

Many different bar code symbologies are available; each has its own rules for encoding characters, printing and decoding, error checking, and other features. Some symbologies only encode numbers; others encode numbers, letters, and punctuation characters.

Other symbologies encode the 128- and 256-character ASCII sets. The newest symbologies encode multiple languages within the same symbol.

Though many symbologies are available, only handfuls are widely used. The most common linear or *one-dimensional* bar code symbologies are—

- Code 39
- Code 128
- UPC (Uniform Product Code), which is used in labeling grocery products and pharmaceuticals
- EAN (European Article Numbering), which will replace UPC in the United States in 2005
- Interleaved 2 of 5 (used by airlines).

Other standards are available today based on 2D stacked and two-dimensional matrix symbologies, but these are only used by organizations that must reduce a large amount of data onto a single bar code. The previously mentioned one-dimensional symbologies are suitable in most circumstances. They are well-established, accurate, and can be produced on different types of media. They can also be read quickly with a variety of scanners and, if desired, from a distance of several meters.

For detailed specifications on bar code symbologies, refer to the barcode-1 website at www.barcode-1.com/pub/russadam/info.html.

How Do You Establish a Symbology?

The most important consideration in selecting a barcode symbology and designing a barcode system is to ensure that your suppliers and/or customers can comply with your specifications. Compliance labeling will enable easier data entry upon receipt, reduce incorrect shipments, and improve overall information availability.

Without industry or supplier/customer standards, Code 39 is the typical non-food standard, only because almost all bar code equipment can read and print this code. However, because Code 39 produces lengthy bar codes, it is not recommended.

Code 128 is a flexible, widely used code because it encodes the full ASCII 128 character set. It can be adopted if the equipment being used can read/print it and an organization's suppliers/customers support it. Code 128 is recommended if your suppliers/customers do not require UPC or EAN (see below).

The UPC, developed for U.S. markets, was first used by the supermarket industry beginning in 1973. UPC assigns unique product codes to registered manufacturers. Anyone interested in establishing a unique code for their product must have a UPC assigned to them by the Uniform Code Council.

The EAN is similar to the UPC; it adds country designation characters to the beginning of the code. In Africa, there are country code prefixes for South Africa, Morocco, Algeria, Kenya, Tunisia, and Egypt. This indicates that some manufacturers in these countries are involved in compliance labeling, and that, in these countries, some level of expertise in this technology exists. Most Latin American countries have EAN country code prefixes. EAN will replace UPC in 2005.

Airlines use interleaved 2 of 5 symbology for routing check-in baggage.

Labels

When you design bar code labels, consider adopting symbologies that are already used by suppliers and customers. You should carefully investigate what symbologies suppliers are already using. If most suppliers are using the same symbology, it is advisable to adopt it as the standard, especially if the suppliers already provide bar codes for expiry date and quantity. The suppliers should be contacted to determine the specifications, including how to build the information inside the bar code, what size to print the bar code, and where to place it on the package or container.

In the health care field, many manufacturers and suppliers use either the Health Industry Bar Code supplier labeling standard (HIBC) or UCC (Uniform Code Council)/EAN 128. For more information about HIBC, visit the website of the Health Industry Business Communications Council (HIBCC) at www.hibcc.org. For more information about EAN 128, review the UCC at www.uc-council.org.

If most suppliers are not providing bar code labels on their products or if they are not using a common symbology, you can use several possible implementation strategies:

- Mandate in the suppliers' contracts that they provide standardized labels.
- Preprint labels for suppliers and require that they place them on their products.
- Require suppliers to send an advance shipment statement prior to actual shipment so labels can be prepared by the organization before the shipment arrives and then placed on the items as they arrive.
- Design and produce the labels at the time of receipt and place them on the items.

If labels must be produced, it is advisable that you use Code 128 (assuming the equipment can read/print it). It is also recommended that the labels contain bar codes for the item, expiry date, and quantity. Each of these three bar codes should be stacked one on top of the other (not side-by-side), and the codes should be printed in the same location on each label. Finally, each code should also be accompanied by the name of the item, expiry date, and quantity, either in English or in a language native to the developing country.

Scanners

Bar code scanners are optical devices that illuminate a bar code symbol and measure the reflected light. The light waveform data is converted to digital data so it can be processed by a decoder. The decoder is either built into the scanner or exists as a separate plug-in device.

Bar code scanners are usually one of three types: fixed, portable batch, and portable radio frequency (RF).

- Fixed readers remain attached to the central CPU.
- Portable batch readers are battery operated and store data into memory for later batch transfer to the central CPU.
- Portable RF scanners are also battery operated but transmit data in real-time to the central CPU.

Within the three categories mentioned above, you can choose from a wide variety of readers. The readers differ in the following ways:

- intelligence (i.e., does the reader have its own computer?)
- scanning capability (i.e., what can the reader scan and at what distance?)

- durability
- size and weight
- expense.

Non-intelligent Fixed Devices

One example of a low-cost bar code reader is the wand/light pen. These non-intelligent devices are made from about 0.0127 meters of metal or plastic tubing, and are held in the hand while scanning. On the positive side, they are very durable and inexpensive. On the negative side, they require contact with the label, and it is difficult to read them on curved surfaces or long labels. Wands/light pens range in price from U.S.\$150–\$200 (using 2004 pricing).

A second category of non-intelligent scanners is the charge-coupled device (CCD). These devices resemble a handheld gun with a wide horizontal mouth, and are used by some retail merchandise outlets. They are able to scan without moving the reader and are very durable and reliable. They can also read curved surfaces easily. On the negative side, their *depth of field* (i.e., distance from scanned object) ranges from contact to a maximum of 0.1524 meters and their *width of field* (i.e., width of bar code they can read) is limited by the width of the device, so they cannot read long bars. They range in price from U.S.\$200–\$300 (using 2004 pricing).

Infrared laser diode handheld readers are generally only used in dirty environments where infrared light is needed to see the bar codes. They are usually inexpensive (U.S.\$500–\$700 per scanner for non-intelligent models based on 2004 pricing).

Visible laser diode readers are probably the best buy for the money. These handheld gun-like devices were designed for use in warehouses. They are very durable and have excellent depth and width of field. They average about 0.1524–0.3048 meters long, but some can scan up to 10.668 meters away with special reflective long-range labels. They are usually lightweight and have low power consumption. The non-intelligent type costs from U.S.\$250–\$350 per scanner; U.S.\$1,000 on the high end (using 2004 pricing).

Another type is the fixed-mount scanners use either CDD or laser technology. You are most likely to see them at grocery store checkouts, but they are also used in other applications.

Other image scanners can read stacked or 2D matrix symbols.

Intelligent Portable Devices

Intelligent bar code readers (also called portable data terminals) may be required for warehouse operations. They are very useful when data must be entered that cannot otherwise be scanned (this happens often), and a regular keyboard with a terminal is not available. Scanned and keyed data are stored in the portable data terminal until it can be downloaded in a batch to a central computer. These devices often cost between U.S.\$400 and U.S.\$900; \$1,500 is the high end (using 2004 pricing).

If intelligent bar code readers are desired, you should carefully select one with programmable function keys that display at least four lines and is back lit. It should also function in both very hot/humid and very cold environments.

Radio Frequency Devices

Radio frequency (RF) devices are the best solution to many warehouse needs. Warehouse applications, picking, and putaways are typically better performed by RF readers, because the computer can instruct the operator where to go and what to do. In addition, because they operate in real-time, they access current data from the central computer.

Generally, two categories of RF devices are available: devices that emulate a terminal and devices that work from *screen maps* created on the central CPU. The terminal emulation types are usually expensive and have additional programming requirements.

If RF is desired, then *screen-mapped* RF devices are recommended because of the ease of programming the remote terminals from the central computer. The software can be expensive (U.S.\$2,000 to \$5,000 based on 2004 pricing), but this option is still less expensive than terminal emulation.

Different RF devices operate on different sets of radio frequencies—narrow band, spread spectrum, and 2.4 GHz spread spectrum.

- Narrow band RF devices operate on a single frequency and have slow data transmission rates (between 2400 and 9600 baud).
- Spread spectrum devices operate over multiple frequencies, resist interference, work off a network, and process high numbers of transactions with data rates of up to 196 Kbps.
- The 2.4 GHz spread spectrum devices operate over multiple frequencies and are fast (up to 1.6 Mbps) but they can only transmit up to 250 feet.

The choice of an RF device is, of course, dependent on the location. In typical warehouses (less than 76.2 meters in any direction), the 2.4 GHz devices function best. They are, however, expensive at U.S.\$2,500 per scanner and U.S.\$2,000 per network hookup (using 2004 pricing).

How to Select a Scanner

The primary concern when selecting a scanner is its compatibility with the software with which it will interact. Ask the manufacturer or distributor of the scanner to demonstrate that the scanner can work with the desired software.

It is equally important that you can have the scanner serviced in-country. In many developing countries, the scanner selection process is limited by the availability of companies to support the product in the country.

If, as happens frequently, the software can interact with a variety of scanners and the scanners are all serviceable in-country, then the choice of a scanner depends primarily on the sophistication required and the available funds. If price is not an issue and the size of the warehouse makes it inefficient for staff to travel back and forth to receive picking orders, then radio frequency or intelligent portable devices would be suitable choices.

Conversely, if the warehouse is a small- to medium-size, then non-intelligent fixed devices connected to a computer (with available keyboard) can usually provide the necessary functionality. Because of the limitations on wands and CCD scanners, neither infrared laser diodes nor fixed-mount scanners are recommended. Infrared laser diodes require special ink with carbon, and they are, therefore, not recommended due to high recurrent costs. Fixed-mount scanners are not recommended for warehouse operations because they require the scanned items to be held. Consequently, if you want non-intelligent fixed devices, visible laser diode scanners are probably the best choice.

Printers

Bar code labels can be printed on-site using any number of printers, including dot matrix, thermal direct, thermal transfer, ink jet, and laser. On-site printing usually takes place at or near the point of use. The data are usually variable, and are entered by an operator through a keyboard or downloaded from a computer.

For on-site printing, you will probably need to purchase label design software, as well as the printer. Most of the available labeling software uses a WYSIWYG design interface and displays the label on screen as it is being designed. The programs usually allow scalable fonts, support all popular bar codes, provide an easy custom operator interface, and have a built-in label database.

Because dot matrix, thermal, and laser printers are in such widespread use, labeling software that will make these printers capable of printing bar codes is readily available. However, you should consult the manufacturer of the labeling software to determine the recommended printers, because the software may be better suited for particular types and makes of printers. Common labeling software packages cost from U.S.\$700 to \$3,000 (using 2004 pricing).

Dot Matrix/Ink Jet/Laser Printers

To produce images, dot matrix printers use a moving printhead to make multiple passes over a ribbon. An image is formed as these passes create rows of overlapping dots on the substrate (underlying layer). Though they are a good choice for producing reports, dot matrix printers are usually not recommended for producing bar codes; because their low density printing results in longer, sometimes unreadable, bar codes. They range in price from U.S.\$300 to \$400; U.S.\$1,500 at the high end (using 2004 pricing).

Ink jet printers use a fixed printhead with a number of tiny orifices that project minute droplets of ink onto a substrate to form an image made up of overlapping dots. Primarily used for in-line direct marking on products or containers, they range in price from U.S.\$200 to \$500; U.S.\$2,500 at the high end (using 2004 pricing).

Laser printers use a controlled laser beam to produce an image that is formed on an electrostatically charged, photo-conductive drum. The charged areas attract toner particles that are transferred and fused onto a substrate. They range in price from U.S.\$200 to \$500; U.S.\$1,000 high end (using 2004 pricing).

Often, laser printers are the preferred option for printing labels because the printers can be used for multiple purposes. One possible drawback to using laser printers is that they require more expensive, pre-gummed labels or, alternatively, require the application of adhesives to the label as a second process. Another disadvantage of laser printers is that excessive friction or moisture can adversely affect the readability of labels.

Direct Thermal/Thermal Transfer Printers

Direct thermal printers produce labels by selectively heating elements in the printhead to form an image on a heat-sensitive substrate made from overlapping dots. Thermal direct printers are generally not recommended because they require special heat-sensitive paper, produce labels that fade over time, and have limited shelf life in high-heat environments. They range in price from U.S.\$300 to \$500; U.S.\$1,200 at the high end (based on 2004 pricing).

Thermal transfer printers use a printhead that is similar to direct thermal printers, except that an intervening ribbon with resin-based or wax-based ink is heated and transfers the image from the ribbon to the substrate. Where serviceable and affordable, thermal transfer printers are the recommended option for producing barcode labels. Although they are expensive (they range from U.S.\$600 to \$1,500; U.S.\$3,500 at the high end based on 2004 pricing), these printers produce outstanding quality on relatively heat-resistant paper. If this printer is selected, it is important to buy the ribbon, labels, and printer from the same source. Because particular thermal transfer labels will only work with a specific ink, if you buy all ribbons and labels from the same source, at least initially, the vendor will be able to guarantee that these products will work together.

How to Select a Printer

As mentioned earlier, when selecting printers for use in developing country settings, the most important consideration is whether the equipment is serviceable in-country. For this reason alone, you should take care before purchasing a thermal transfer printer. The organization purchasing the printer should be certain that enough spare parts are in-country to service any part of the machine.

If service is the most important issue, a laser printer is probably the best choice. They are usually serviceable in-country and can produce suitable high-density labels. However, because it may be difficult to find the right adhesive labels for laser printers in developing countries, you may need to add your own adhesive substance (e.g., glue) to the laser-generated labels. Such adhesive should be strong enough to withstand rough handling and hot/humid environments.

Dot matrix printers are the poorest option because of their low density printing. Because it is probably inevitable that small items will be barcoded at some point, you should avoid dot matrix printers.

When selecting a printer, the manufacturer of the labeling software should be consulted prior to purchase, because some printers are better suited than others to a manufacturer's software. It is also wise to purchase labeling software from a manufacturer that can provide support for this software in-country. If this is not possible, then software support via email is highly recommended (phone support would be too expensive).

Verifiers

As bar coding has become more and more critical to a company's success, the cost of failure has also become more significant. If a customer cannot read the barcode you produce, it is pointless to produce it. For this reason, barcode verification systems are now commonly used at sites producing barcodes.

Verifiers check the acceptability of a barcode based on ANSI's published criteria, known as the Bar Code Print Quality Guideline. These devices can be attached to the printer to monitor the quality of every label, or they can be used as a stand-alone to audit batches of labels for quality. They range in price from U.S.\$900 to \$2,000 (using 2004 pricing).

When Should You Consider Bar Coding?

When implemented properly, barcoding can provide a myriad of benefits to an organization's supply chain management, including—

- more accurate inventory control for a large number of items
- fewer shipping and receiving errors
- more timely tracking of receipts, shipments, and stock
- better warehouse management (FEFO).

Barcoding also has the potential to reduce or even eliminate the need for cumbersome manual recordkeeping and reporting procedures. Any training associated with these procedures would also be reduced or eliminated.

Note: However, training in barcoding procedures would be required.

Before you decide to implement a barcoding system, consider the following:

- First, and perhaps most important, is the up-front cost of introducing the system. To implement a barcoding system in an average-size warehouse could cost anywhere from U.S.\$20,000 to \$30,000 (using 2004 pricing) for just the hardware and labeling software. This cost does not include any application software. Application software can cost tens of thousands of U.S. dollars, depending on its functionality. If consultants need to draw up specifications for the system, install it, and train staff on its use, then the cost of implementation rises steeply. Overall, a typical system would cost U.S.\$150,000 to \$200,000 (using 2004 pricing).
- The recurrent costs of maintenance, software support, and consumables must be considered in any decision to introduce barcoding. Consumable costs are the highest. It costs, on average, 4 to 5 U.S. cents (using 2004 pricing) to produce one single 0.1524 meter label using a thermal transfer device (7 U.S. cents for polyester labels, which are thermally most stable). The cost of these labels can be reduced if you use common laser printers. If adhesive labels are not used, adhesive must be applied as a separate process, which may be time-consuming and still result in a high percentage of damaged labels.
- The availability of maintenance support for hardware should also be a major consideration in the decision to barcode. It is crucial that in-country maintenance support be available for the input devices and associated hardware that interfaces to the central computer. Because the central computer and printers will probably be name brands, maintenance support should already be available for these devices (thermal printers may be an exception).
- An organization must be prepared to manage the organizational changes that will occur after barcoding is introduced. Not only must top management be committed to the implementation of the new system, but it must also prepare for the changes in staffing. At least two individuals must be trained to administer the application software and manage the overall system. Many other individuals will have to be trained to use the scanning equipment and the new procedures for warehouse management.

In summary, barcoding should be considered if—

- Warehouse volume and turnover is sufficiently high (i.e., the time spent by workers completing either automated or manual recordkeeping and reporting is hampering efforts to process receipts, putaways, picks, or shipments in a reasonable time).
- Sufficient funding is available to cover the up-front cost of purchasing and installing a complete system, including all necessary hardware and software.
- Sufficient future funding is available to cover the recurrent costs of equipment maintenance, software support, and consumable items.
- At least two people are available with sufficient technical skill to operate the labeling software and any application software for managing the warehouse.
- A reasonably steady supply of electricity is available to all locations where barcoding equipment will be used.

Barcoding Equipment Manufacturers and Dealerships

There are many barcoding equipment manufacturers, distributors, and value-added retailers. Manufacturers and distributors provide barcode scanning devices, printers, verifiers, and other related equipment. Value-added retailers may also supply this equipment and they often provide additional services, including installation, system development, and maintenance.

The Association for Automatic Identification and Mobility (AIM) is a global trade association for the Automatic Identification and Data Capture (AIDC) industry, and it provides an online buyers guide to AIDC company information. The company's website has a search engine that enables any user to identify the websites of any and all manufacturers, distributors, and value-added retailers of any and all types of barcoding equipment. Users can find technology information, solutions, hardware, software, and standards for the entire AIDC industry through its website at www.aimglobal.org.

WMS Implementation

Two important points to keep in mind when implementing a WMS are (1) unlike a logistics management information systems (LMIS) that must be custom-developed, WMSs are widely available as commercial, off-the-shelf software packages ready for installation; and (2) implementing a WMS typically requires a significant financial investment. Organizations in the private sector often spend up to several million U.S. dollars to implement a WMS complete with radio frequency communication and barcoding technology.

These two factors should influence the process for implementing a WMS in several ways. The generally high cost of WMS implementation should lead to an early focus on justifying this cost: what are the benefits—both monetary and intangible—to the organization for investing in a WMS, and when will the investment pay off? In addition, the availability of various packaged WMS software should guide the development of a solution: the activities in these phases will likely concentrate on the identification and selection of a packaged WMS rather than the design of custom-developed software.

While individual WMS implementations vary in their techniques, the process for implementing a WMS usually includes the following activities:

- develop an effective business case for a WMS
- form a WMS project team
- analyze warehouse needs
- define the WMS solution type
- select a WMS vendor
- test the WMS
- train users
- conduct rollout.

Each of these activities is described in more detail in the following sections.

Forming a WMS Project Team

Without exception, implementing a WMS in a warehouse is a major undertaking that depends on the considerable efforts of a team composed of warehouse personnel. Moreover, after the WMS is implemented, it will significantly change warehouse operations. For these reasons, it is important that you form a WMS project team at

the outset of the implementation. It is not sufficient for warehouse personnel to assist the implementation only part-time—such an approach will lead to failure. A project that will bring major changes to the warehouse requires careful planning and the full attention of warehouse personnel throughout the process.

The key member of the project team is the team leader; he or she coordinates all implementation activities (described later) and guides the process forward. This is not a part-time role; the team leader should be able to commit most of his or her time to the WMS implementation.

Developing an Effective Business Case for a WMS

The two major challenges in building a business case for a WMS are (1) quantifying benefits of a WMS into *expected* financial savings or returns, and (2) using an applicable financial decision-making approach to compare savings and returns for the required WMS investment and maintenance costs. Some general tools for meeting these challenges are described in the next session.

Quantifying Benefit of a WMS

While the bulk of the investments in a WMS tend to be made upfront (see next section), the benefits of WMS are often experienced after the WMS has been implemented and time has past, as management decisions are increasingly guided by more punctual and multi-faceted inventory reports. When quantifying benefits of a WMS, therefore, you must be able to identify those warehouse practices that are likely to change after a WMS is implemented.

Benefits from WMS accrue in two major warehouse cost areas:

- labor
- inventory and inventory carrying costs.

Labor

These include cost benefits related to reductions in labor required or to more productive labor. Within a warehouse, labor is typically divided into three areas: direct, indirect, and administrative. Examples are listed in table 11.

Table 11: Warehouse Labor Types

Labor Type	Examples
Direct	<ul style="list-style-type: none"> ■ Receiving ■ Storing ■ Picking ■ Packing ■ Shipping
Indirect	<ul style="list-style-type: none"> ■ Supervision ■ Training
Administrative	<ul style="list-style-type: none"> ■ Customer service ■ Data processing ■ Reporting

General cost reductions experienced in the private sector and more developed economies (Alexander Communications Group, Inc. 2002) suggest that labor benefits can be more than 50 percent of the financial benefits of WMS. This includes up to—

- 20 percent improvement in direct labor productivity
- 30 percent improvement in indirect labor productivity
- 75 percent improvement in administrative labor productivity.

While salaries are also a high-cost budget item in most public sector warehouses in resource-constrained environments, the relatively lower cost of labor in these economies may make labor cost reductions less of a concern for warehouses. Still, improvements in labor productivity are clearly a motive for implementing a WMS, especially in an environment where competition for and shortage of a skilled workforce are increasingly significant.¹

Inventory and Inventory Carrying Costs

The primary costs associated with inventory are the monetary value of safety stock required to avoid stockouts, and the value of products that expire, are damaged, or are lost. Other inventory carrying costs include any fees charged for shipping/receiving or importing products, including customs duties or demurrage charges, taxes and/or insurance paid on the value of products in inventory, and the storage space required.

Earlier, five major benefits of a WMS were described. Table 12 suggests potential measures that could be used to quantify these benefits, in financial terms. Appendix 2A provides brief examples and descriptions of these parameters and how to measure them (These tools were developed in MS Excel).

Table 12: Potential Cost Savings from WMS

Potential Benefit	Potential Cost Savings
Zero information errors	<ul style="list-style-type: none"> ■ Percentage and equivalent cost of labor time devoted to inventory counts ■ Percentage and equivalent cost of labor time devoted to resolving inventory discrepancies
Reduced information lead times	<ul style="list-style-type: none"> ■ Percentage of labor and equivalent cost devoted to the generation of warehouse reports (for example, days) versus percentage of time expected to be associated with WMS (for example, minutes) ■ Percentage of labor and equivalent cost devoted to forecasting versus percentage of time expected to be taken with WMS ■ Lost revenue from capital tied in buffer stock—for example, from higher value or higher margin products
Increased labor productivity	<ul style="list-style-type: none"> ■ Percentage expected and equivalent cost of direct and indirect labor time saved: for example, receiving, storing, picking, packing, shipping, supervision/quality assurance, training, data service, and reporting
Increased storage capacity	<ul style="list-style-type: none"> ■ Percentage reduction in buffer stock ■ Carrying cost saving ■ Value of inventory write-off

Ultimately, the measures you use to assess cost saving areas depends on the business processes that are currently in place in the warehouse, including management of warehouse information systems and decision making using warehouse or inventory data. In most cases, the measures relate to savings from increasing labor productivity, which is achieved by reducing personnel time in the warehouse, directly or indirectly.

Financial Decision-Making Approach

You will find significant challenges in comparing the costs with the benefits of a WMS. One challenge relates to the time gap between when an investment is made in a WMS and when the benefits accrue (described earlier). Another challenge and dimension to the time is that the cost *and* the benefits of a WMS accrue over time, yet decisions have to be made in the present. Finally, making a business case for a WMS hinges on being able to assess that the monetary capital that will be tied up in a WMS would not be better spent on other projects (i.e., that the financial return from a WMS is adequate or higher than an alternative proposition).

You can use several approaches to address these challenges and to evaluate the benefit of a WMS relative to its cost. The approaches vary in their degree of complexity, both relative to each other and in the application of a given approach. Possible approaches that have been used include payback period analysis, net present value analysis, and internal rate-of-return analysis.

Payback Period Analysis

Based on future cash inflows, this method measures the time it will take to recoup the total value of the investment made in a capital project, such as a WMS.

Payback period = amount invested in WMS/annual incremental cash inflow

For example, an initial investment of \$100,000 is required in the first year to implement a WMS, and the expected annual benefits/savings from the WMS are about \$40,000 over the next three years. The payback period is 2.5 years (\$100,000 divided by \$40,000). Note that this is also shorter than the expected duration of benefits from a WMS (three years), suggesting that the WMS will more than pay for itself.

The acceptable period depends on the warehouse and may vary based on the value of the money at the time of the investment (i.e., the importance of having the cash that would otherwise be tied up in a WMS, or the existence of other competing projects that could be implemented). With this method, projects with shorter payback periods are preferred, as are projects that recoup their cost before the end of their lifespan (typically not an issue with WMS projects). However, by focusing mainly on time, the method does not consider the inherent profitability of the project.

Net Present Value Analysis

This method calculates the expected net monetary gain or loss from a project by discounting all future cash inflows and outflows to the present point in time when a decision about investment in WMS is being made. Discounting is a financial calculation that expresses future cash flows (inflows or outflows) in terms of their value in the present. The financial premise for the calculation is that a dollar today is worth more than a dollar in the future; the main reason for this is that cash in hand today can earn interest and grow over time. Therefore, the discount rate reflects the value of this interest and is used to calculate the present value of cash flows that occur in the future, using the following formula:

$$\text{Present value} = (\text{future cash flow}) / (1 + \text{discount rate})^y$$

where y is the number of years in the future

Net present value is calculated by subtracting the present value of future cash *inflows* from the present value of future cash *outflows*. A positive net present value (or net present value equal to zero or break even) is a sign to proceed with the project.

Using the example above, assume that the discount rate is 8 percent. The present value of the cash outflow is \$100,000, because the investment (outflow) is made in the present time or year 0. The present value of inflows (benefits) is \$103,084, based on the sum of the annual discounted present value of benefits as seen in table 13. Included in appendix 2B is a table of the single multiplier or factor that can be used to calculate the present value of equal inflows of \$1.00 for various discount rates and the life of a project. In this example, notice that the multiplier or factor at an 8 percent discount rate over three years is 2.577 (in appendix 2b, see row 3 for the third year [Year 3] and column 4 for the 8 percent discount rate); therefore, \$40,000 multiplied by 2.577 is \$103,080 (difference due to rounding).

Table 13: Present Value Calculation Example

	Year 0	Year 1	Year 2	Year 3	Total
Value of \$40,000 benefit in each year	n/a	\$ 37,037	\$ 34,294	\$ 31,753	\$ 103,084
Value of \$100,000 cost in year	\$100,000	n/a	n/a	n/a	\$ 100,000

The net present value of the investment is \$3,084; therefore, an investment in a WMS is justifiable because it will, at least, more than recover its cost.

Projects with the higher net present values are preferred if all other things are equal. The discount rate used in calculating present value is an important factor that influences the outcome of net present value calculations.

Internal Rate-of-Return Analysis

This method calculates the interest rate or discount rate at which the present value of cash inflows equals the present value of cash outflows. The analysis favors investments with higher internal rates of return and those with a rate higher than the required rate of return, i.e., the rate of return that allows an organization to recover the cost of the investment plus any interest paid on borrowing for that investment. To use this method, there must be a single required rate of return against which the internal rate of return can be compared (i.e., the method cannot handle different rates for different future years).

For the example above, the internal rate of return is the rate at which the following equation can be solved:

$$\text{\$100,000} = \text{\$40,000} \times (1 + \text{internal rate of return for 3-year period})$$

$$2.5 = (1 + \text{internal rate of return for 3-year period})$$

Using the present value of an annuity table in appendix 2B, in the row related to year 3, the discount rate that is related to a multiplier or factor close to 2.5 is between 8 percent and 10 percent. Assuming the required rate for the example is 8 percent, the WMS investment can be considered financially acceptable.

What Approach is Best for Analyzing the Financial Impact of a WMS?

The most commonly used financial analysis for making a business case for a WMS is the net present value analysis; we recommend this methodology in this guideline. Its strongest advantage is that it factors the time value of money (unlike the payback period approach) and allows benefits to be expressed in monetary terms (unlike the internal rate-of-return approach). Net present value analysis also enables decision makers to estimate the effect of accepting a combination of projects (by adding the net present value of independent projects). Major steps to implement the net present value analysis include the following:

1. Project the cash inflows (i.e., savings) and outflows that would result from a WMS project over time. A simple approach is to estimate the savings that would accrue in year one and assume this is maintained over time. The same can be done for the recurring costs of maintaining a WMS. See appendix 2A for variables to consider when estimating the cost of a WMS. Appendix 2A also provides guidelines for estimating the expected benefits of a WMS.
2. Calculate the present value of the cash inflows and outflows based on an applicable discount rate (or required rate of return) and the number of years that benefits are expected to accrue, and determine the net present value of the project.

3. Conduct a sensitivity analysis on the results of the calculation by estimating the change in net present value based on changing the assumptions inherent to the calculation. For example, evaluate the effect on net present value of changes in the savings from benefit categories and changes in discount rates. Sensitivity analysis is a technique that assesses how a result will change if predicted data are not achieved or underlying assumptions change.

Table 14 summarizes a sensitivity analysis for the example presented under the Net Present Value section. Part I of the table shows that by changing/increasing the presumed *life* of the WMS project, the cost benefit of an investment in a WMS becomes increasingly attractive, holding the discount rate constant. Increasing the expected rate of return or discount rate of the WMS project does not decrease the attractiveness of the project if the expected life of project is more than 3 years (NPV is still positive). Part II of the table shows that the attractiveness of the project is sensitive to the expected annual benefit of a WMS. In particular, assuming that the benefits from a WMS last 3 years (a relatively conservative assumption based on Part I findings), the table shows that investment in the WMS would not be justified if annual benefits were \$20,000 or less.

Table 14: Sensitivity Analysis for Net Present Value Calculations

Part I: Net Present Value with:		<i>Discount rate of—</i>			
		6%	8%	10%	20%
<i>Duration of benefits (years)</i>	3	\$ 6,920	\$ 3,084	\$ (526)	\$ (15,741)
	5	\$ 68,495	\$ 59,708	\$ 51,631	\$ 19,624
	10	\$ 194,403	\$ 168,403	\$ 145,783	\$ 67,699
	20	\$ 358,797	\$ 292,726	\$ 240,543	\$ 94,783
Part II: Net Present Value with:		<i>Discount rate for 3 years of—</i>			
		6%	8%	10%	20%
<i>Value of benefits</i>	\$ 20,000	\$ (46,540)	\$ (48,458)	\$ (50,263)	\$ (57,870)
	\$ 40,000	\$ 6,920	\$ 3,084	\$ (526)	\$ (15,741)
	\$ 60,000	\$ 60,381	\$ 54,626	\$ 49,211	\$ 26,389
	\$ 80,000	\$ 113,841	\$ 106,168	\$ 98,948	\$ 68,519

Issues to Consider When Applying Financial Analyses

The focus in building a business case for a WMS has primarily been on quantifying the financial benefits of a computerized system. However, the weakness in this approach is that some costs (or financial benefits) are unknown or cannot be easily known. To address this weakness, the following should be considered when evaluating the case for whether or not to invest in a WMS:

- Be prepared and consider the qualitative and financial benefits for a WMS. Several sources point to these types of benefits, linked primarily to the organization and business process improvement that can be achieved with a WMS. For example, be prepared to discuss and evaluate the impact of the proposed system on employee satisfaction, workload management, customer responsiveness, cycle time, product visibility, and improved procurement/buying practices.
- Other quantitative but non-financial benefits are also important and should be considered and evaluated. Sources, for example, document the impact of a WMS on the speed of response to orders due to the increased flexibility of a WMS. This, in turn, can be evaluated in terms of improvements in customer service; for example, the percentage of orders shipped on schedule, the percentage of ordering periods where no stockouts occurred, or the reduction in lost sales. Another quantifiable area used to evaluate a WMS is the reduction in error rates for the completion of orders, the procurement of products, or in warehouse reporting.

Analyzing Warehouse Needs

After the costs of implementing a WMS have been justified, the next major activity is an analysis of the needs of the warehouse. During the analysis, participants in a WMS implementation project attempt to answer, in detail, the following questions:

- How does the current warehouse information system work?
- How is the information collected, processed, and presented?
- What decisions are being made?
- What information is needed to make those decisions?

A sample requirements analysis document can be found in the *Guidelines for Implementing Computerized Logistics Management Information Systems (LMIS)* (JSI/DELIVER 2003).

Defining the WMS Solution Type

WMS software can be classified into three types:

1. *Commercial, off-the-shelf (COTS) software.* This ready-to-install, packaged software is commercially available, and is designed specifically to support warehouse management.
2. *Enterprise resource planning (ERP) software.* ERP software tries to integrate all departments; it functions within an organization with a single computerized system. Because many organizations include storage and distribution functions, many ERPs contain a WMS component. In many ERP implementations, only selected components of the ERP are made operational.
3. *Custom-developed software.* This software is designed and developed to meet the needs of a particular warehouse.

Criteria for Choosing a WMS Solution Type

Given the various types of solutions that can be applied, how do you determine the best solution to fit the needs of a particular warehouse? The following simple criteria can guide this decision.

- *If the warehouse uses standard business processes for receiving, storing, and distributing products, a COTS software solution will be the most cost effective.*
- *If the warehouse must share data with other departments, such as accounting or human resources, an ERP solution may be the most efficient way to integrate with other departments.*
- *If the warehouse has unusual business processes that provide a competitive advantage, but that cannot be supported by a packaged WMS, a custom-developed solution tailored to support those unique business processes will best fit the needs of the warehouse. Because so many packaged WMSs are available, this is not the most cost-effective solution, but it will be the most effective solution overall.*

Selecting a WMS Vendor

Most warehouses use standard business processes that can be supported with a COTS or ERP solution. In these cases, the next activity in implementing a WMS is to identify potential solutions and select one vendor after reviews and demonstrations of the solution are offered. To select a vendor (1) develop an initial list of vendors, (2) solicit and evaluate vendor bids, and (3) select a vendor that has a WMS or ERP solution that best meets the needs of the warehouse.

Developing an Initial List of Vendors

Warehouse managers that are considering implementation of a COTS or ERP solution can choose from hundreds of vendors. The Internet is the best way to begin identifying potential vendors and solutions. The following two websites focus on information technologies that support supply chains, and the sites contain links to many WMS vendors:

- *supplychain.ittoolbox.com*
- *www.scs-mag.com*

If the initial list of vendors is too long, you can use a number of criteria to trim the list:

- *Vendor viability:* How many installations exist now and what is their market share?
- *Technical environment:* What hardware is required and what is its ability to interface or integrate with other software?
- *Industry experience:* What solution has proven successful within the industry?
- *Functional requirements:* What software can support current and future business processes described in the requirements analysis document? Is it flexible and easy to use?
- *Cost:* What is the total cost to operate the solution, including software, hardware, implementation, training, and on-going support.

(Barnes 2003)

To collect data for these criteria, you will probably need to contact each vendor by email or phone. The vendors will readily provide some data, but other pieces of information, such as the total cost to operate the WMS, may be more difficult to obtain at this early stage.

Soliciting and Evaluating Vendor Bids

The WMS project team can solicit vendor bids in one of two ways: (1) publish a notice in one or more newspapers or magazines (prequalification), or (2) publish an open tender inviting vendors to bid on the proposed WMS or ERP system.

When bids from vendors begin to arrive, the project team evaluates each bid by comparing it to the business processes listed in the requirements analysis document. Three or four vendors offering solutions that best match the business processes are then invited to present a demonstration of their solutions to the WMS project team.

Following the demonstrations, the WMS project team selects the vendor whose solution best meets the needs outlined in the requirements analysis document.

Testing the WMS

Testing is one of the most important steps in the process of implementing a WMS, but it may not receive sufficient resources when most of the attention is focused on identifying and evaluating possible WMS solutions. In addition, project participants may assume that packaged WMS or ERP software has already been tested many times by the vendor and by other clients, and, therefore, does not need to be tested prior to their own implementation. This erroneous assumption may lead to implementation failure when the WMS cannot meet the particular needs of the warehouse. Every WMS—packaged or custom-developed—must be tested prior to implementation, both to verify that it supports the business processes of the warehouse and to identify components or functions that require modification.

WMSs handle routine operations well, such as issuing products according to a customer order. What WMSs often don't handle as well are the exceptions to the rule—for example, receiving a quantity larger than the quantity ordered. Testing how the WMS deals with these exceptional circumstances will uncover problems or gaps in WMS functions that must be addressed prior to putting the WMS into operation. A test plan that includes extensive testing for exceptions will not only save money (by fixing the software before it is installed), but will also reduce the likelihood of a system failure when an unforeseen exception arises.

Testing for both routine and exceptional events takes place in a *conference room pilot*, in which the WMS project team uses representative data from the warehouse to verify that the WMS or ERP solution can support the particular operations of the warehouse. While the WMS or ERP solution is demonstrated by the vendor during the selection phase, the warehouse controls the conference room pilot in this phase. In preparation, the WMS project team develops scripts or scenarios that outline the steps involved in carrying out both routine and unusual tasks. During the pilot, the WMS project team makes note of any modifications that need to be made before the system can be put into operation. The system is then returned to the vendor for further customization. If the list of requested modifications is long, another pilot may be scheduled to test the modifications.

Training Users

Training warehouse personnel to operate the new system is often seen as one of the last steps in the WMS implementation process. In fact, formal training activities—either structured on-the-job training or competency-based training in a classroom setting—typically take place just before the new system is put into operation. But, including warehouse personnel in the WMS project team at the beginning of the implementation process—during analysis of the existing system and design of the new

system—will greatly increase the chances for a successful WMS implementation. Employees from all areas of the warehouse who are members of the project team can help develop training content that focuses on real-life warehouse operations and includes procedures for handling exceptions.

Instructing warehouse personnel on how to use the new system to receive and issue products may help launch the WMS, but it is not a sufficient training approach in the long run. To answer the following types of questions, warehouse managers must understand how to use the WMS:

- Is there a sufficient quantity of each product in the warehouse to meet all existing customer orders?
- How much of each product needs to be purchased during the next procurement cycle to meet demand?
- Are any products in the warehouse going to expire before they can be issued?

Packaged WMSs and ERP systems usually have many reports that analyze warehouse performance, and they include answers to these questions. In addition, these packages include tools for writing custom reports that are tailored to the needs of a particular warehouse.

Rollout

The WMS or ERP solution has been selected (or developed) and tested, and warehouse personnel have been trained. The solution is now ready to be *rolled out* or put into operation. The WMS team has worked diligently to get to this stage, and they are looking forward to a break. Yet a successful rollout phase requires just as much preparation and planning as the earlier activities. From the following list, the WMS team can select one approach for the rollout:

- *Parallel processing*: In this approach, the existing and new systems operate at the same time. This is the lowest-risk approach but also the most time-consuming.
- *Full cutover*: In this approach, warehouse personnel stop using the existing system when the new WMS is put into operation. This is the most common approach, but also the most dangerous because it does not provide a backup option in case the new system fails.
- *Phased-in processing*: This approach entails dividing the new system into functional units (for example, receiving, picking, and shipping) and selecting either a parallel or cutover approach for each functional unit. It mitigates the risk of the full cutover approach because a poorly performing function can be temporarily removed while the rest of the system continues to operate. But, it also requires more time to develop links between components of the current and new systems.

Computerized WMS Solutions

Computerized WMS and ERP solutions have been implemented in several countries where JSI/DELIVER provides technical assistance, and they are briefly described below:

Intellitrack

In September 2003, DELIVER assisted in an implementation of the Intellitrack WMS at the headquarters of Retro-CI, an HIV/AIDS research project based in Côte d'Ivoire and managed by CDC in partnership with the Ministry of Health. After DELIVER's

January 2002 assessment of stock management procedures, the team recommended the implementation of a computerized LMIS. The WMS was configured to track storage and distribution of stocks managed by the virology, clinical biology, and pharmacy departments at project headquarters.

Broadline

In 2003, JSI, a subcontractor to Crown Agents on a World Bank-funded project, helped implement the Broadline WMS at the Ministry of Health's central warehouse in East Timor. In addition to basic WMS functions, the software included components for procurement tracking and pipeline monitoring. Following the implementation, at the request of Crown Agents, Broadline Computer Systems made additional enhancements to the software.

Orion

With financial support from the Danish development agency DANIDA, the Medical Stores Department in Tanzania launched a project in 2001 to implement a computerized WMS. The implementation process included these steps:

1. The business processes of the warehouse were analyzed and described in a requirements document that was published for bid by interested vendors.
2. The project team reviewed bids submitted by vendors, and selected the Orion ERP, based on the fit with requirements and the availability of local supply and support.
3. Components of the ERP were implemented as follows: finance, procurement, sales, and inventory/warehousing.

Lessons Learned

Accurate Stock on Hand Data Are the Key to Implementation Success

The most important task warehouses face is tracking how much stock is on hand, where it is, and when it will expire. Accordingly, the essential data in a WMS are data on quantities and locations of stock on hand. Experiences implementing a WMS in Côte d'Ivoire and ERP in Tanzania demonstrate that accurate stock on hand data are the foundation of a successful implementation. In Côte d'Ivoire, delays in gathering these data halted the use of the WMS in one department because the WMS could not support distribution of products that were not recorded as being in stock. In Tanzania, the challenge of collecting up-to-date inventory data led the project team to implement other modules first (finance, sales, and procurement), even though these modules did not directly support the main task of tracking stock.

Local Technical Support Is Critical to Continued WMS Operations

Most commercial WMS vendors are based in developed countries; few off-the-shelf WMSs have been developed and marketed in developing economies. Accordingly, the implementation team will often select a WMS package with a record of successful installations in the U.S. and Europe. But, if the selected WMS does not have a local partner that can provide ongoing technical support, its implementation is unlikely to succeed.

Every warehouse must constantly adapt to a changing business environment, and WMS operations must be modified continuously. Without a local source of technical support, the warehouse has to rely on external firms to provide support, which may prove too expensive and time-consuming for warehouses in developing countries to acquire. A local partner can provide technical support faster and cheaper, and can make adjustments to the WMS as soon as they are needed. (see table 15).

Table 15: WMS Solutions

	Intellitrack	Broadline	Orion	Navision	SIGMED
Country of implementation	Côte d'Ivoire	East Timor	Tanzania	Uganda	Malawi
Type of system	WMS	WMS	ERP	ERP	WMS
Vendor	Intellitrack	Broadline Computer Systems Pvt. Ltd.	ICICI (India)	Microsoft	MedICT
Database	Microsoft Access 2000	SQL Server	Oracle		
License cost		U.S.\$45,000			
Website	www.intellitrack-.net	www.broadline-.net	www.icici-infotech.com	www.microsoft.com/businessSolutions/Navision/default.aspx	www.medict.nl

References

- Ackerman, Kenneth. 1986. *Practical Handbook of Warehousing*. Washington, D.C.: The Traffic Service Corporation.
- Ackerman, Kenneth, B. 1992. *Words of Warehousing*. Columbus, Ohio: The K. B. Ackerman Company.
- Alexander Communications Group, Inc. 2002. *Warehouse Management and Control Systems*. New York: Alexander Communications Group, Inc.
- Allen, Mary Kay, and Ormar K. Helferich. 1990. *Putting Expert Systems to Work in Logistics*. Oak Brook, Ill.: Council of Logistics Management.
- Association for Automatic Identification and Mobility. <http://www.aimglobal.org>. (accessed June 2004)
- Barnes, C. 2003. Warehouse Management Systems Seminar.
- Esync. 2002. *Justifying Warehouse Management Systems*. Toledo, Ohio: Esync.
- Frazelle, Edward. 2002. *World-Class Warehousing and Material Handling*. New York: McGraw-Hill Book Company.
- Grey, Stephen L. 1983. *Warehouse Operations: A Handbook*. Beaverton, Oregon: M/A Press.
- Health Industry Business Communications Center. <http://www.hibcc.org>. (accessed June 2004)
- Horngren, C. T., and G. Foster. 1991. *Cost Accounting: A Managerial Emphasis*. Seventh Edition. New Jersey: Prentice Hall.
- John Snow, Inc./DELIVER. 2003. *Guidelines for Implementing Computerized Logistics Management Information Systems*. Arlington, Va.: DELIVER, for the U.S. Agency for International Development.
- Keeney, Alexander. 1988. "Personnel Planning." *The Warehouse Management Handbook*. James Tompkins and Jerry Smith, eds. New York: McGraw-Hill Book Company.
- Kronslev, P. 2004. *Experiences of Implementing an Enterprise Resource Planning (ERP) System at the Medical Stores Department, Tanzania*. N.p.
- Napolitano, Maida. 1994. *The Time, Space & Cost Guide to Better Warehouse Design: A Hands-on guide to help you improve the design and operations of your warehouse or distribution center*. New York: Alexander Research & Communications, Inc. Distribution Center Management.
- Smith, Jerry, and J. Eric Peters. 1988. "Warehouse Space and Layout Planning." *The Warehouse Management Handbook*. James Tompkins and Jerry Smith, eds. New York: McGraw-Hill Book Company.
- Tompkins, James A., and Jerry D. Smith. 1988. *The Warehouse Management Handbook*. New York: McGraw-Hill Book Company.
- Uniform Code Council, Inc. <http://www.uc-council.org>. (accessed July 2004)
- The Warehousing Research Center. 1997. *A Guide for Establishing Warehouse Job Descriptions*. Oak Brook, Ill.: Warehousing Education and Research Council.
- Rack Manufactures Institute. 2002. *Specification for the Design, Testing and Utilization of Industrial Steel Storage Racks*. Charlotte, N.C.: Rack Manufactures Institute.

Appendix 1: WMS Reports

Picking List

Central Medical Stores
Ministry of Health

Picking List

Date: 22-Jan-2004
Time: 17:23
Pages: 1 of 1

Order 12345
Due Date 23-Dec-2003
Ship Date 22-Dec-2003
Ship To Cheetah Lake District Hospital

Product	Description	Ordered Qty	Shipped Qty	Balance	Comments
234567	Amoxicillin tablet 250 mg	1000	0	1000	
					Location UOM On Hand Qty Exp Date
					A02 {Each} 10,000 30-Jun-2006
345678	Nevirapine susp 5 mg/ml	500	0	500	
					Location UOM On Hand Qty Exp Date
					B04 {Each} 200 30-Jun-2005
					B05 {Each} 800 30-Nov-2005

Inventory by Location

Central Medical Stores
Ministry of Health

Inventory by Location

Date: 22-Jan-2004
Time: 17:23
Pages: 1 of 1

Product	Description	UOM	On Hand Qty	Extended Qty	Exp Date
Location: A01					
123456	Amoxicillin tablet 250 mg	{Each}	5,000	5,000	31-Oct-2004
234567	Nevirapine susp 5 mg/ml	{Each}	400	400	30-May-2004
Location: A02					
345678	Determine HIV Test	{Each}	500	500	31-Mar-2004
Location: B01					
456789	Condom 52 mm	{Box}	1,000	10,000	31-Dec-2005
Location: B02					
567890	Progesterone tablet calendar pack	{Each}	8,000	8,000	30-Jun-2005
678901	Norplant® 36 mg levonogestrel	{Each}	700	700	31-Mar-2005

Inventory by Expiration DateCentral Medical Stores
Ministry of Health**Inventory by Expiration Date**Date: 22-Jan-2004
Time: 17:23
Pages: 1 of 1

Exp Date	Location	UOM	On Hand Qty	Extended Qty	%
Product: 567890 Progesterone tablet calendar pack					
31-Jan-2004	B02	{Each}	500	500	25%
31-Jul-2004	B03	{Each}	1,500	1,500	75%
Product: 678901 Norplant® 36 mg levonogestrel					
28-Feb-2004	B04	{Each}	200	200	67%
31-Aug-2004	B05	{Each}	100	100	33%

Open Customer OrdersCentral Medical Stores
Ministry of Health**Open Customer Orders**Date: 22-Jan-2004
Time: 17:23
Pages: 1 of 1

Order #	Customer Name	User ID	Order Date	Due Date	Ship Date
12345	Cheetah District Hospital	Mohammed	12-Dec-2003	31-Dec-2003	
Product	Description	Ordered Qty	Shipped Qty	Balance	Comments
234567	Amoxicillin tablet 250 mg	1,000	0	1,000	
345678	Condom 52 mm	10,000	5,000	5,000	
456789	Progesterone calendar pack	5,000	0	5,000	

Closed Customer Orders

Logistics System
Ministry of Health

Closed Customer Orders

Date: 22-Jan-2004
Time: 17:23
Pages: 1 of 1

Order #	Customer Name	User ID	Order Date	Due Date	Ship Date
12345	Cheetah District Hospital	Mohammed	08-Aug-2003	30-Sep-2003	

Product	Description	Ordered Qty	Shipped Qty	Balance	Comments
234567	Amoxicillin tablet 250 mg	1,500	1,500	0	
345678	Condom 52 mm	8,000	8,000	0	
456789	Progesterone calendar pack	5,000	5,000	0	

Open Purchase Orders

Central Medical Stores
Ministry of Health

Open Purchase Orders

Date: 22-Jan-2004
Time: 17:23
Pages: 1 of 1

Order #	Supplier Name	User ID	Order Date	Due Date	Receive Date
78901	Smith Diagnostics	Mohammed	08-Aug-2003	30-Sep-2003	28-Sep-2003

Product	Description	Ordered Qty	Received Qty	Balance	Comments
234567	Determine HIV Test balance will be sent in Feb 2004	20,000	10,000	10,000	Per vendor
345678	Determine Reagent	10,000	0	10,000	

Closed Purchase OrdersCentral Medical Stores
Ministry of Health**Closed Purchase Orders**Date: 30-Mar-2004
Time: 17:23
Pages: 1 of 1

Order #	Supplier Name	User ID	Order Date	Due Date	Receive Date
78901	Smith Diagnostics	Mohammed	08-Aug-2003	30-Sep-2003	15-Feb-2004

<u>Product</u>	<u>Description</u>	<u>Ordered Qty</u>	<u>Received Qty</u>	<u>Balance</u>	<u>Comments</u>
234567	Determine HIV Test	20,000	20,000	0	
345678	Determine Reagent	10,000	10,000	0	

Appendix 2: WMS Tools

2A. WMS Cost Justification Worksheet

Cost Element	Information Required to Measure
Percentage (and equivalent cost) of labor time devoted to inventory counts.	<ul style="list-style-type: none"> ■ Number of inventory counts in a year expected to be unnecessary with WMS. ■ Number of personnel involved in each inventory count. ■ Amount of time (e.g., days) devoted to each inventory count by each personnel on average → calculate percentage of time per personnel devoted per year, based on: (# of counts × time devoted per count)/available personnel time per year. ■ Average salary of personnel, per year (include salary plus benefit).
Percentage (and equivalent cost) of labor time devoted to resolving inventory discrepancies.	<ul style="list-style-type: none"> ■ Number of personnel involved in resolving discrepancies. ■ Percentage of their time devoted to resolving discrepancies in a year (e.g., based on number of days devoted in a year). ■ Average salary of personnel, per year (include salary plus benefit).
Percentage of labor (and equivalent cost) devoted to generation of warehouse reports (e.g., days) versus percentage of time expected to be taken with WMS (e.g., minutes).	<ul style="list-style-type: none"> ■ Number of personnel involved in generating reports. ■ Percentage of their time devoted to generating reports in a year on average (e.g., based on number of days devoted in a year). ■ Average salary of personnel, per year (include salary plus benefit).
Percentage of labor (and equivalent cost) devoted to forecasting versus percentage of time expected to be devoted to WMS.	<ul style="list-style-type: none"> ■ Number of times forecasts or procurement planning occurs in a year. ■ Number of personnel involved in forecasting. ■ Amount of time (e.g., days) devoted to forecasting by each personnel, on average, minus amount of time that is expected to be devoted to forecasting with WMS → calculate result as a percentage of time per personnel devoted per year based on: (# of events × time devoted per event)/available personnel time per year. ■ Average salary of personnel, per year (include salary plus benefit).
Percentage expected (and equivalent cost) of direct and indirect labor time saved (e.g., receiving, storing, picking, packing, shipping, supervision/quality assurance, training, data service, reporting).	<ul style="list-style-type: none"> ■ Major functions that will probably be affected by having WMS. ■ Number of people involved. ■ Percentage of their time that will be saved, on average, (based on percentage of time devoted to function now minus percentage of time they expect to spend on the function with WMS)². ■ Average salary of personnel per year (include salary plus benefit).

WMS Cost Justification Worksheet (continued)

Cost Element	Information Required to Measure
Percentage reduction in buffer stock ³ .	<p>Option 1:</p> <ul style="list-style-type: none"> ■ Length of order cycle. ■ Estimated expected reduction in lead time for shipping products (i.e., time it currently takes to prepare reports for processing product shipment versus total lead time for filling order); express time as percentage of length of order cycle (e.g., reduction by 2 weeks in a 2-month order cycle is 25 percent). ■ Value of average shipment in order period (based on average quantity and value of total shipment per order cycle). ■ → calculate value of percentage reduction in buffer stock: multiply value of shipment by percentage reduction in lead time. <p>Option 2:</p> <ul style="list-style-type: none"> ■ Estimated expected reduction in lead time (e.g., in months; express time as percentage of a month (e.g., reduction by 2 weeks is 50 percent). ■ Value of total inventory shipped last year. ■ → calculate value of percentage reduction in buffer stock: multiply total shipment value by percentage reduction in lead time.
Carrying cost saving	<p>Based on estimate of the above reduction in buffer stock:</p> <ul style="list-style-type: none"> ■ Estimate of carrying costs as percentage of value of inventory held in stock (i.e., carrying cost fee or mark-up). Can be obtained from accounting office. Carrying costs include any fees charged for shipping/receiving or importing products, including customs duties or demurrage charges, taxes, and/or insurance paid on the value of products in inventory, and costs related to storage space (e.g., staff, equipment, utilities, and maintenance)⁴. ■ Using estimate above of value of reduction in buffer stock → calculate carrying cost savings: multiply value of reduced stock by percentage carrying cost fee.
Value of inventory write-off	<ul style="list-style-type: none"> ■ Including products that have expired, been lost, become obsolete (e.g., reagents for no-longer performed tests). ■ Total value of inventory written-off in the last year (e.g., based on the type of product, quantity of product written-off, and unit cost [or average purchase price] of product). ■ Percentage estimated reduction in inventory write-off → to calculate value of inventory write-off, multiply this percentage by the total value of inventory written off.

Endnotes

- ¹ The function that is affected and amount of time saved will vary depending on the business processes of the warehouse; therefore, data should be completed for the areas most relevant to the warehouse and operations.
- ² The function that is affected and amount of time saved will vary depending on the business processes of the warehouse; therefore, data should be completed for the areas most relevant to the warehouse and operations.
- ³ Two *complications* can be factored in when estimating the savings from reduced buffer stock, but, for simplicity, they are not included here: (1) the interest cost that would have been paid on the money used to purchase the buffer stock. This assumes that the warehouse needs to borrow cash to procure stock, and this cost may be important if the interest rate for loan is significant. (2) The projected annual growth in demand (hence, stock held) because higher levels of stock would be held, the savings would increase in proportion to annual growth rate. See reference for Alexander Communications Group 2002 for information on how these two factors can be included.
- ⁴ Note that reductions in demurrage charges can be factored separately. Use demurrage fee (for example, expressed as per value of stock in demurrage) and multiply by the value of the reduced stock. Alternatively, to determine the estimated savings in demurrage charges, multiply demurrage costs (for example, for the last year) by estimate of expected percentage reduction in demurrage cost.

Assumptions and Inputs

Complete Sections Highlighted in:

Click for:

Labor-related

Inventory, carrying cost-related

Financial calculations

Labor related Comments

1	Number of working days -- full-time personnel	220	
2	Average salary+benefits of warehouse personnel, by category	Annual	Per day, calculated
	Warehouse personnel category 1	-	-
	Warehouse personnel category 2	-	-
	Warehouse personnel category 3	-	-
	Warehouse personnel category 4	-	-
	Warehouse personnel category 5	-	-
3	Time (in days per year) currently devoted to generating reports (including data entry and processing) by personnel involved	# of personnel in category	Days
	Warehouse personnel category 1	0	0
	Warehouse personnel category 2	0	0
	Warehouse personnel category 3	0	0
	Warehouse personnel category 4	0	0
	Warehouse personnel category 5	0	0
4	Time (in days) currently devoted to each forecasting/ procurement planning event by personnel involved each by category	# of personnel in category	Days
	Warehouse personnel category 1	0	0
	Warehouse personnel category 2	0	0
	Warehouse personnel category 3	0	0
	Warehouse personnel category 4	0	0
	Warehouse personnel category 5	0	0

Inventory and carrying cost related Comments

1	Average shipment cycle (in months)	-	
2	Value of average shipment per shipment cycle	-	
	or		
3	Value of total shipments last year (indicated if figure is sales or cost of goods sold)	-	<input type="checkbox"/> Sales <input type="checkbox"/> Cost of Goods Sold
4	Value of inventory written-off in last year due to expiration, damage or 'loss' to poor inventory tracking (e.g., based on type of product, quantity of product written-off and unit cost of product)	-	

Estimates of Labor Time Savings:

Instructions:

Complete Sections Highlighted in: 

Also, Verify Assumptions: 

A. Reduced frequency of physical inventory counts **\$ -**

1	Expected number of unnecessary inventory counts		0
2	Time (in days) devoted by personnel involved in each inventory count, on average	# of personnel in category	Days devoted by each personnel, avg.
	Warehouse personnel category 1	0	0
	Warehouse personnel category 2	0	0
	Warehouse personnel category 3	0	0
	Warehouse personnel category 4	0	0
	Warehouse personnel category 5	0	0

 ← Verify Assumptions

B. Savings in time devoted to resolving inventory discrepancies **\$ -**

1	Time (in days per year) devoted to resolving discrepancies by personnel involved (including resolving shipping errors)	# of personnel in category	Days devoted by each personnel, avg.
	Warehouse personnel category 1	0	0
	Warehouse personnel category 2	0	0
	Warehouse personnel category 3	0	0
	Warehouse personnel category 4	0	0
	Warehouse personnel category 5	0	0

 ← Verify Assumptions

C. Time saved in generating warehouse reports **\$ -**

1	Expected time (in days per year) that would be devoted to generating reports by personnel involved (including data entry and processing) with WMS	# of personnel in category	Days devoted by each personnel, avg.
	Warehouse personnel category 1	0	0
	Warehouse personnel category 2	0	0
	Warehouse personnel category 3	0	0
	Warehouse personnel category 4	0	0
	Warehouse personnel category 5	0	0

 ← Verify Assumptions

D. Improved forecasting, procurement planning **\$ -**

1	Number of forecasting/procurement planning events per year		0
2	Expected time (in days) that would be devoted with WMS to each forecasting/procurement planning event by personnel involved	# of personnel in category	Days devoted by each personnel, avg.
	Warehouse personnel category 1	0	0
	Warehouse personnel category 2	0	0
	Warehouse personnel category 3	0	0
	Warehouse personnel category 4	0	0
	Warehouse personnel category 5	0	0

 ← Verify Assumptions

E. Other expected time savings in direct or indirect labor **\$ -**

1	Expected time savings (in days per year) by personnel involved, e.g., in receiving, storing, picking, packing, shipping, supervision/quality assurance, training, data service, reporting	# of personnel in category	Days saved by personnel, on average
	Warehouse personnel category 1	0	0
	Warehouse personnel category 2	0	0
	Warehouse personnel category 3	0	0
	Warehouse personnel category 4	0	0
	Warehouse personnel category 5	0	0

 ← Verify Assumptions

Estimates of Inventory and Carrying Cost Savings:

Instructions:



F. Reduction in Buffer Stock	-		
Approach 1 - Based on Average Shipment Value per Order Cycle			
1 Expected reduction (in months) in lead time (including reduction in time to prepare reports, resolve errors)	0.5		
Approach 2 - Based on total Annual Inventory Shipped			
1 Expected reduction (in months) in lead time (including reduction in time to prepare reports, resolve errors)	0.5		

Value of reduced stock, calculated	0
Value of reduced stock, calculated	0

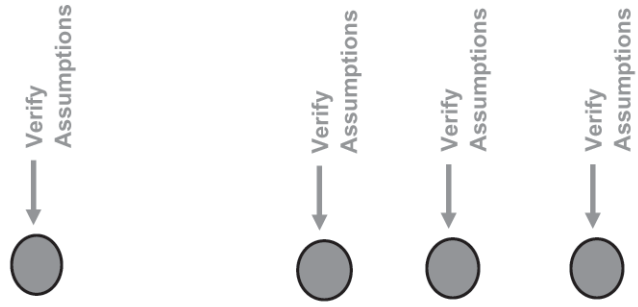

G. Savings in Carrying Costs	-
1 Carrying costs as % of inventory value (including fees for customs, demurrage, taxes, insurance, and storage, equipment and maintenance costs)	0%

H. Value of inventory write-off	\$
1 % estimated reduction in inventory write-off	0%

I. Lost revenue in capital tied in buffer stock	-
1 % average margin for Class A, i.e., high price high volume, products (margin is % of selling price over buying price)	0%

Total Cost of Warehouse Management System

	<u>Total Cost</u>
Initial implementation costs	-
a) Software	
WMS or ERP license	-
Database license	-
b) Hardware	
Server	-
Printers	-
Workstations	-
Radio frequency access points	-
Bar code scanners	-
c) Implementation services	
Implementation project management	-
WMS or ERP software customization	-
Integration with other software applications	-
Annual recurring costs	-
a) Maintenance	
Salary of information system manager	-
Hardware repair	-
WMS or ERP software enhancements	-
b) Bar code supplies	
Labels	-
Ink	-

Financial Analysis of WMS Investment

A. Reduced frequency of physical inventory counts	\$	-
B. Savings in time devoted to resolving inventory discrepancies	\$	-
C. Time saved in generating warehouse reports	\$	-
D. Improved forecasting, procurement planning	\$	-
E. Other expected time savings in direct or indirect labor	\$	-
F. Reduction in Buffer Stock		
G. Savings in Carrying Costs		
H. Value of inventory write-off	\$	-
I. Lost revenue in capital tied in buffer stock		



Total Estimated First Year Savings	-
Present Value of Savings	-
Total Estimated Warehouse Management System Cost	\$

Financial Analysis Assumptions

Discount Rate	10%
Number of years for NPV	10

Net Present Value	-
Payback period	-
	in years
	in months

Years	2.0%	4%	6%	8%	10%	12%	14%	16%	18%	20%	22%	24%	26%	28%	30%	32%	40%	Years
1	0.980	0.962	0.943	0.926	0.909	0.893	0.877	0.862	0.847	0.833	0.820	0.806	0.794	0.781	0.769	0.758	0.714	1
2	1.942	1.886	1.833	1.783	1.736	1.690	1.647	1.605	1.566	1.528	1.492	1.457	1.424	1.392	1.361	1.331	1.224	2
3	2.884	2.775	2.673	2.577	2.487	2.402	2.322	2.246	2.174	2.106	2.042	1.981	1.923	1.868	1.816	1.766	1.589	3
4	3.808	3.630	3.465	3.312	3.170	3.037	2.914	2.798	2.690	2.589	2.494	2.404	2.320	2.241	2.166	2.096	1.849	4
5	4.713	4.452	4.212	3.993	3.791	3.605	3.433	3.274	3.127	2.991	2.864	2.745	2.635	2.532	2.436	2.345	2.035	5
6	5.601	5.242	4.917	4.623	4.355	4.111	3.889	3.685	3.498	3.326	3.167	3.020	2.885	2.759	2.643	2.534	2.168	6
7	6.472	6.002	5.582	5.206	4.868	4.564	4.288	4.039	3.812	3.605	3.416	3.242	3.083	2.937	2.802	2.677	2.263	7
8	7.325	6.733	6.210	5.747	5.335	4.968	4.639	4.344	4.078	3.837	3.619	3.421	3.241	3.076	2.925	2.786	2.331	8
9	8.162	7.435	6.802	6.247	5.759	5.328	4.946	4.607	4.303	4.031	3.786	3.566	3.366	3.184	3.019	2.868	2.379	9
10	8.983	8.111	7.360	6.710	6.145	5.650	5.216	4.833	4.494	4.192	3.923	3.682	3.465	3.269	3.092	2.930	2.414	10
11	9.787	8.760	7.887	7.139	6.495	5.938	5.453	5.029	4.656	4.327	4.035	3.776	3.543	3.335	3.147	2.978	2.438	11
12	10.575	9.385	8.384	7.536	6.814	6.194	5.660	5.197	4.793	4.439	4.127	3.851	3.606	3.387	3.190	3.013	2.456	12
13	11.348	9.986	8.853	7.904	7.103	6.424	5.842	5.342	4.910	4.533	4.203	3.912	3.656	3.427	3.223	3.040	2.469	13
14	12.106	10.563	9.295	8.244	7.367	6.628	6.002	5.468	5.008	4.611	4.265	3.962	3.695	3.459	3.249	3.061	2.478	14
15	12.849	11.118	9.712	8.559	7.606	6.811	6.142	5.575	5.092	4.675	4.315	4.001	3.726	3.483	3.268	3.076	2.484	15
16	13.578	11.652	10.106	8.851	7.824	6.974	6.265	5.668	5.162	4.730	4.357	4.033	3.751	3.503	3.283	3.088	2.489	16
17	14.292	12.166	10.477	9.122	8.022	7.120	6.373	5.749	5.222	4.775	4.391	4.059	3.771	3.518	3.295	3.097	2.492	17
18	14.992	12.659	10.828	9.372	8.201	7.250	6.467	5.818	5.273	4.812	4.419	4.080	3.786	3.529	3.304	3.104	2.494	18
19	15.678	13.134	11.158	9.604	8.365	7.366	6.550	5.877	5.316	4.843	4.442	4.097	3.799	3.539	3.311	3.109	2.496	19
20	16.351	13.590	11.470	9.818	8.514	7.469	6.623	5.929	5.353	4.870	4.460	4.110	3.808	3.546	3.316	3.113	2.497	20
21	17.011	14.029	11.764	10.017	8.649	7.562	6.687	5.973	5.384	4.891	4.476	4.121	3.816	3.551	3.320	3.116	2.498	21
22	17.658	14.451	12.042	10.201	8.772	7.645	6.743	6.011	5.410	4.909	4.488	4.130	3.822	3.556	3.323	3.118	2.498	22
23	18.292	14.857	12.303	10.371	8.883	7.718	6.792	6.044	5.432	4.925	4.499	4.137	3.827	3.559	3.325	3.120	2.499	23
24	18.914	15.247	12.550	10.529	8.985	7.784	6.835	6.073	5.451	4.937	4.507	4.143	3.831	3.562	3.327	3.121	2.499	24
25	19.523	15.622	12.783	10.675	9.077	7.843	6.873	6.097	5.467	4.948	4.514	4.147	3.834	3.564	3.329	3.122	2.499	25
26	20.121	15.983	13.003	10.810	9.161	7.896	6.906	6.118	5.480	4.956	4.520	4.151	3.837	3.566	3.330	3.123	2.500	26
27	20.707	16.330	13.211	10.935	9.237	7.943	6.935	6.136	5.492	4.964	4.524	4.154	3.839	3.567	3.331	3.123	2.500	27
28	21.281	16.663	13.406	11.051	9.307	7.984	6.961	6.152	5.502	4.970	4.528	4.157	3.840	3.568	3.331	3.124	2.500	28
29	21.844	16.984	13.591	11.158	9.370	8.022	6.983	6.166	5.510	4.975	4.531	4.159	3.841	3.569	3.332	3.124	2.500	29
30	22.396	17.292	13.765	11.258	9.427	8.055	7.003	6.177	5.517	4.979	4.534	4.160	3.842	3.569	3.332	3.124	2.500	30
35	24.999	18.665	14.498	11.655	9.644	8.176	7.070	6.215	5.539	4.992	4.541	4.164	3.845	3.571	3.333	3.125	2.500	35
40	27.355	19.793	15.046	11.925	9.779	8.244	7.105	6.233	5.548	4.997	4.544	4.166	3.846	3.571	3.333	3.125	2.500	40



John Snow, Inc.

1616 North Fort Myer Drive, 11th Floor

Arlington, VA 22209 USA

Phone: 703-528-7474

Fax: 703-528-7480

Email: deliver_project@jsi.com

Internet: deliver.jsi.com